

Context-Sensitive Binding by the Laminar Circuits of V1 and V2: A Unified Model of Perceptual Grouping, Attention, and Orientation Contrast

Rajeev D.S. Raizada* and Stephen Grossberg[†]
Department of Cognitive and Neural Systems
Boston University
677 Beacon Street
Boston, MA 02215
Phone: 617-353-7858 or-7857
Fax: 617-353-7755
Email: rajeev@cns.bu.edu, steve@cns.bu.edu

Visual Cognition, forthcoming.
Originally submitted: July 18, 2000. Revised: November 3, 2000

Technical Report CAS/CNS TR-2000-008

Keywords: visual cortex, attention, grouping, orientation contrast, cortical layers, V1, V2, feedback, neural network

*Supported in part by the Defense Advanced Research Projects Agency and the Office of Naval Research (ONR N00014-95-1-0409), the National Science Foundation (NSF IRI 94-01659) and the Office of Naval Research (ONR N00014-92-J-1309 and ONR N00014-95-1-0657).

[†]Supported in part by the Defense Advanced Research Projects Agency and the Office of Naval Research (ONR N00014-95-1-0409), the National Science Foundation (NSF IRI 97-20333) and the Office of Naval Research (ONR N00014-95-1-0657).

Abstract

A detailed neural model is presented of how the laminar circuits of visual cortical areas V1 and V2 implement context-sensitive binding processes such as perceptual grouping and attention. The model proposes how specific laminar circuits allow the responses of visual cortical neurons to be determined not only by the stimuli within their classical receptive fields, but also to be strongly influenced by stimuli in the extra-classical surround. This context-sensitive visual processing can greatly enhance the analysis of visual scenes, especially those containing targets that are low contrast, partially occluded, or crowded by distractors. We show how interactions of feedforward, feedback and horizontal circuitry can implement several types of contextual processing simultaneously, using shared laminar circuits. In particular, we present computer simulations which suggest how top-down attention and preattentive perceptual grouping, two processes that are fundamental for visual binding, can interact, with attentional enhancement selectively propagating along groupings of both real and illusory contours, thereby showing how attention can selectively enhance object representations. These simulations also illustrate how attention may have a stronger facilitatory effect on low contrast than on high contrast stimuli, and how pop-out from orientation contrast may occur. The specific functional roles which the model proposes for the cortical layers allow several testable neurophysiological predictions to be made. The results presented here simulate only the boundary grouping system of adult cortical architecture. However, we also discuss how this model contributes to a larger neural theory of vision which suggests how intracortical and intercor-tical feedback help to stabilize development and learning within these cortical circuits. Although feedback plays a key role, fast feedforward processing is possible in response to unambiguous information. Model circuits are capable of synchronizing quickly, but context-sensitive persistence of previous events can influence how synchrony develops. Although these results focus on how the interblob cortical processing stream controls boundary grouping and attention, related modeling of the blob cortical processing stream suggests how visible surfaces are formed, and modeling of the motion stream suggests how transient responses to scenic changes can control long-range apparent motion and also attract spatial attention.

1 Introduction: Contextual effects and binding in visual cortex

This article continues the development of a neural model aimed at providing a unified explanation of how the laminar circuits of visual cortical areas V1 and V2 interact with the LGN to control cortical development, learning, perceptual grouping, and attention (Grossberg, Mingolla, & Ross, 1997; Grossberg, 1999a; Grossberg & Raizada, 2000; Grossberg & Williamson, 2000; Ross, Mingolla, & Grossberg, 2000). In particular, the model has begun to clarify how preattentive and attentive perceptual mechanisms are intimately linked within the laminar circuits of visual cortex, notably how bottom-up, top-down, and horizontal cortical connections interact within the cortical layers. To this end, we quantitatively simulate a number of phenomena about visual contextual processing, contrast-sensitive grouping and attention to illustrate the model's predictive power. In this regard, it has long been known that a neuron's response to stimuli inside its classical receptive field (CRF) can be strongly influenced by stimuli outside in the surround (e.g. Blakemore & Tobin, 1972; Maffei & Fiorentini, 1976; Nelson & Frost, 1978). Only more recently, however, has the functional importance of these contextual effects for real-world visual processing been widely appreciated (e.g. von der Heydt et al., 1984; Grossberg & Mingolla, 1985; Allman et al., 1985; Gilbert & Wiesel, 1990; Knierim & Van Essen, 1992; Grossberg, 1994; Kapadia et al., 1995; Lamme, 1998; Sillito et al., 1995; Polat et al., 1998; Sugita, 1999).

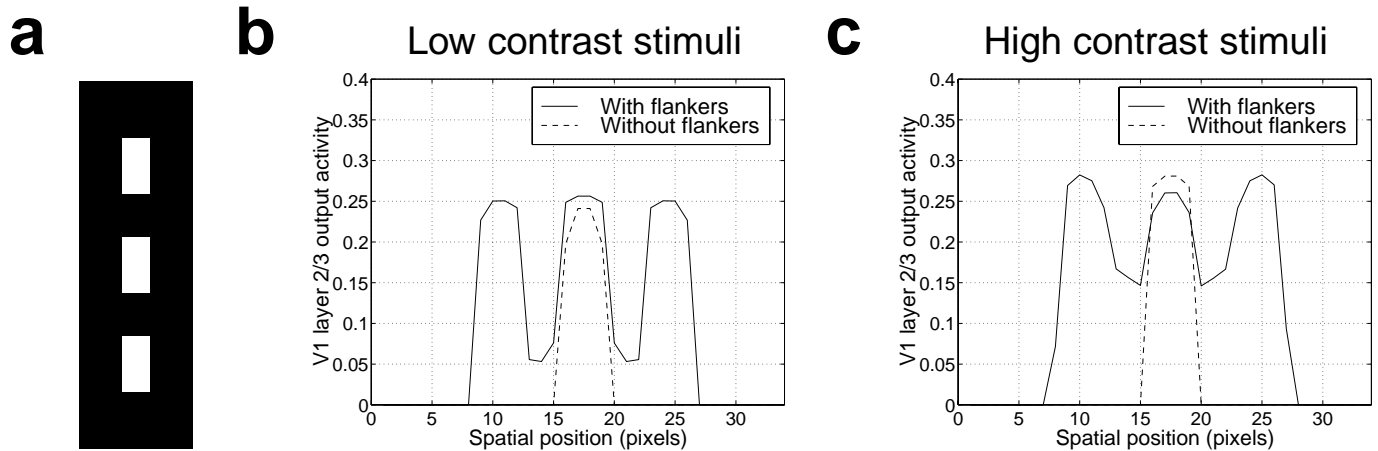

Figure 1: Contrast-dependent perceptual grouping in primary visual cortex, showing how collinear flankers have a net facilitatory effect at low stimulus contrasts, but then “crossover” into being net inhibitory at high contrasts. **(a):** Example stimuli of the sort used by Kapadia et al. (1998), consisting of three bars of equal contrast: a central target bar, and two collinear flankers. The image shown here is an actual stimulus that was presented to the model network. **(b):** Cross-section of V1 layer 2/3 neural activity in the model, in response to low contrast bar stimuli. The solid line shows activity when the target and flankers are presented together, with the responses to each of the bar corresponding to a “hump” of activity in the cross-section. Above-threshold layer 2/3 groupings form between the collinear bars, as shown by the regions of non-zero activity filling the inter-bar spaces. The dotted line shows the neural response to the central target bar alone, presented without any flankers. It can be seen that the target bar elicits more activity when the flankers are present, showing that the grouping has a net facilitatory effect at this low stimulus contrast. **(c):** Same set of V1 layer 2/3 cross-sections as in (b), but now with all three bars presented at high contrast. Strong above-threshold collinear groupings form between the bars, but the net effect of the flankers on the target is nonetheless inhibitory. By “net inhibitory”, we mean that the the central stimulus elicits a weaker response when the flankers are present than when they are absent, with “net facilitatory” meaning the reverse. Thus, the net facilitatory effect of the flankers in panel (b) can be seen by the fact that the solid with-flankers activity trace is above the dotted without-flankers line. In panel (c), the relative positions of these two lines have switched, indicating that the flankers have now “crossed over” into being net inhibitory.

A particularly vivid example of a contextual effect is the collinear grouping of oriented stimuli, which enhances the detection of grouped targets (Polat & Sagi, 1993; Kapadia et al., 1995) and of smooth contours (Field, Hayes, & Hess, 1993; Kovacs & Julesz, 1993), and which also gives rise to the percept of illusory contours (Kanizsa, 1979) when the inducing stimuli also cause a brightness difference across the two sides of the collinear group (Grossberg & Mingolla, 1985; Grossberg, 1994). Psychophysical evidence suggests that grouping occurs without the need for top-down attention (Moore & Egeth, 1997). Perceptual grouping mechanisms are particularly needed for detecting targets which are surrounded by distractors or which are of low contrast. The relevance of contrast for such grouping is further illustrated by recent neurophysiological studies of cortical area V1 which have shown that the contextual effects are contrast-dependent, with low-contrast targets being facilitated by collinear flankers, but high-contrast targets being depressed, as shown in Figure 1 (Polat et al., 1998; Kapadia, Westheimer, & Gilbert, 1998).

Top-down attention can also be viewed as a form of contextual processing, in that it plays an important role when a target is surrounded by distractors, but may have much less effect when a target is presented on its own (Motter, 1993; De Weerd et al., 1999). Attentional effects have been observed

throughout visual cortex, including many recent studies of attention in V1 (e.g. Roelfsema et al., 1998; Watanabe et al., 1998; Somers et al., 1999; Ito & Gilbert, 1999; Brefczynski & DeYoe, 1999). Like collinear grouping, attention also has its greatest facilitatory effect when the target is low contrast, as illustrated in the study by De Weerd et al. (1999, data shown in Figure 2c). Moreover, attention interacts in important ways with other contextual effects, in particular with grouping: attention can spread itself along visual groupings (He & Nakayama, 1995; Davis & Driver, 1997), and can propagate along both real and illusory contours (Roelfsema & Spekreijse, 1999; Moore, Yantis, & Vaughan, 1998), as illustrated in Figures 4 and 5. We have elsewhere argued that top-down attention and related feedback pathways are mechanisms whereby the cortex can stabilize its initial development and subsequent learning (Grossberg, 1980, 1999a, 1999b; Grossberg & Williamson, 2000).

Another important contextual effect is orientation contrast, in which an element whose orientation differs from that of its neighbors “pops out” from the background. Such effects have been observed psychophysically, and also neurophysiologically in V1 (Nothdurft, 1991; Knierim & Van Essen, 1992; Sillito et al., 1995; Nothdurft et al., 1999). Like grouping, this mechanism is particularly useful for picking out targets which are surrounded by distractors, as shown for example in Figure 3.

The process of visual binding is very closely related to these contextual processes; it too is needed most when the visual scene is cluttered with distractors. Indeed, when there is just a single visual element in a display the binding problem cannot arise. It is therefore unsurprising that many experimental studies of binding have concentrated on the effects discussed above, in particular grouping and attention (for recent reviews, see Gray (1999) on the relations between binding and Gestalt grouping, and Reynolds and Desimone (1999) and Treisman (1999) on binding and attention).

Discussions of the neural processes underlying binding are often somewhat vague. In this article, we will attempt to address this problem by proposing specific and testable neurophysiological substrates for two visual processes which are fundamental for binding, namely attention and grouping. In particular, we suggest detailed laminar circuits in V1 and V2 for implementing these processes, and propose ways in which they can interact with each and with other visual contextual mechanisms. Computer simulations from a neural network implementation of this architecture will be presented, demonstrating the viability of the proposed scheme and illustrating the details of its operation. Although the model proposed here concentrates primarily on the spatial aspects of binding, rather than possible relations to temporal phenomena such as neural synchronization, it has elsewhere been shown that variants of this model are capable of rapidly synchronizing their emergent states during both perceptual grouping and attentional focusing; see Grossberg and Somers (1991) and Grossberg and Grunewald (1997). An important but often overlooked aspect of visual binding is also addressed by the present model: the question of how the information distributed across different cortical regions, and across different cortical layers within the same region, can be bound together. We suggest specific mechanisms of intercortical and intracortical feedback which allow the different layers and regions of cortex to mutually influence and even synchronize their visual processing. On the other hand, our results also illustrate how a very fast bottom-up sweep of information through the cortex can be sufficient if the visual stimuli are sufficiently unambiguous.

1.1 Doing different types of contextual processing at once: the preattentive/attentive interface problem for cortex and for cortical models

The neurophysiological studies mentioned above provide compelling evidence that the processes of preattentive perceptual grouping and top-down visual attention coexist within the same cortical

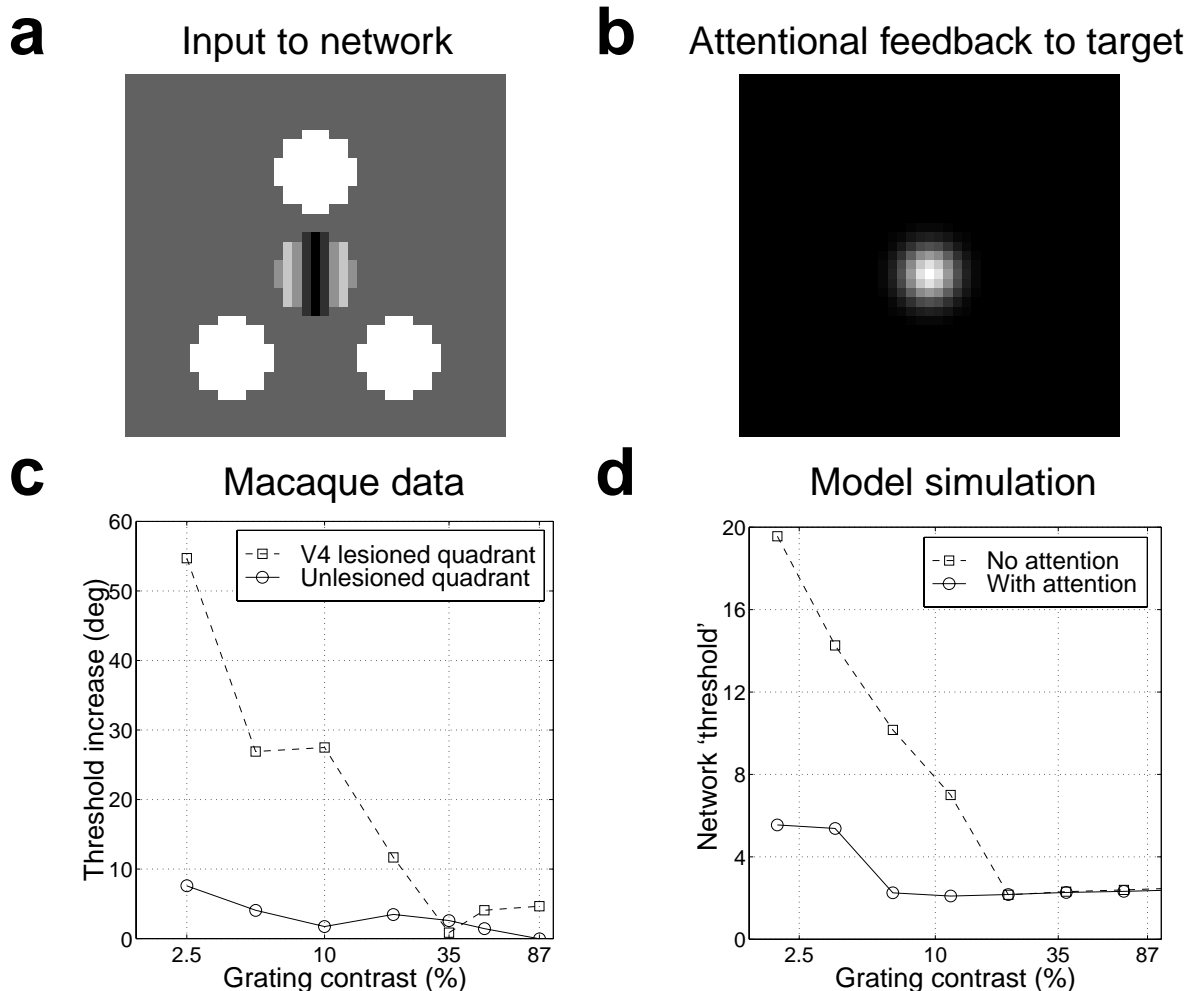

Figure 2: Attention has a stronger facilitatory effect on low contrast stimuli than it does at high contrasts, as shown in the study by De Weerd et al. (1999) and the model’s simulation of it. **(a):** Example stimuli of the sort used by De Weerd et al., consisting of a variable-contrast oriented grating surrounded by three distractor discs. The image shown here is an actual stimulus that was presented to the model network. **(b):** Attentional feedback directed in the model to the location of the target grating, implemented simply as a diffuse Gaussian of corticocortical feedback activity. **(c):** Data from the macaque study, reproduced with permission from De Weerd et al. (1999, Fig.3b). The solid line with circles shows the monkeys’ orientation discrimination thresholds when the target and distractors were presented in an unlesioned visual quadrant, hence with intact top-down attention. Task performance was very good across all conditions, even when the target grating was very low contrast. The dashed line with squares shows that when the stimuli were presented in a visual quadrant from which V4 had been lesioned, hence impairing top-down attention, task performance was still good at high grating contrasts, but degraded significantly as the contrast reduced. Hence, top-down attention has more of an effect on low contrast stimuli. **(d):** Model simulation of the Deweerd et al. data. In the model, attention can simply be turned on and off, rather than by having to lesion any higher-level cortical areas. Indeed, these higher task-encoding areas, presumably in prefrontal and inferotemporal cortex, are not simulated in the present model, which considers only V1 and V2. Thus, the Gaussian of attention is positioned over the target grating by specifying its coordinates in the simulation computer program, rather than by being steered by a simulated higher cortical area. The network’s “behavioral threshold” is simply operationalized as the reciprocal of V1 layer 2/3 oriented activity, since these are the cells which pass information about the grating’s orientation forward to higher areas.

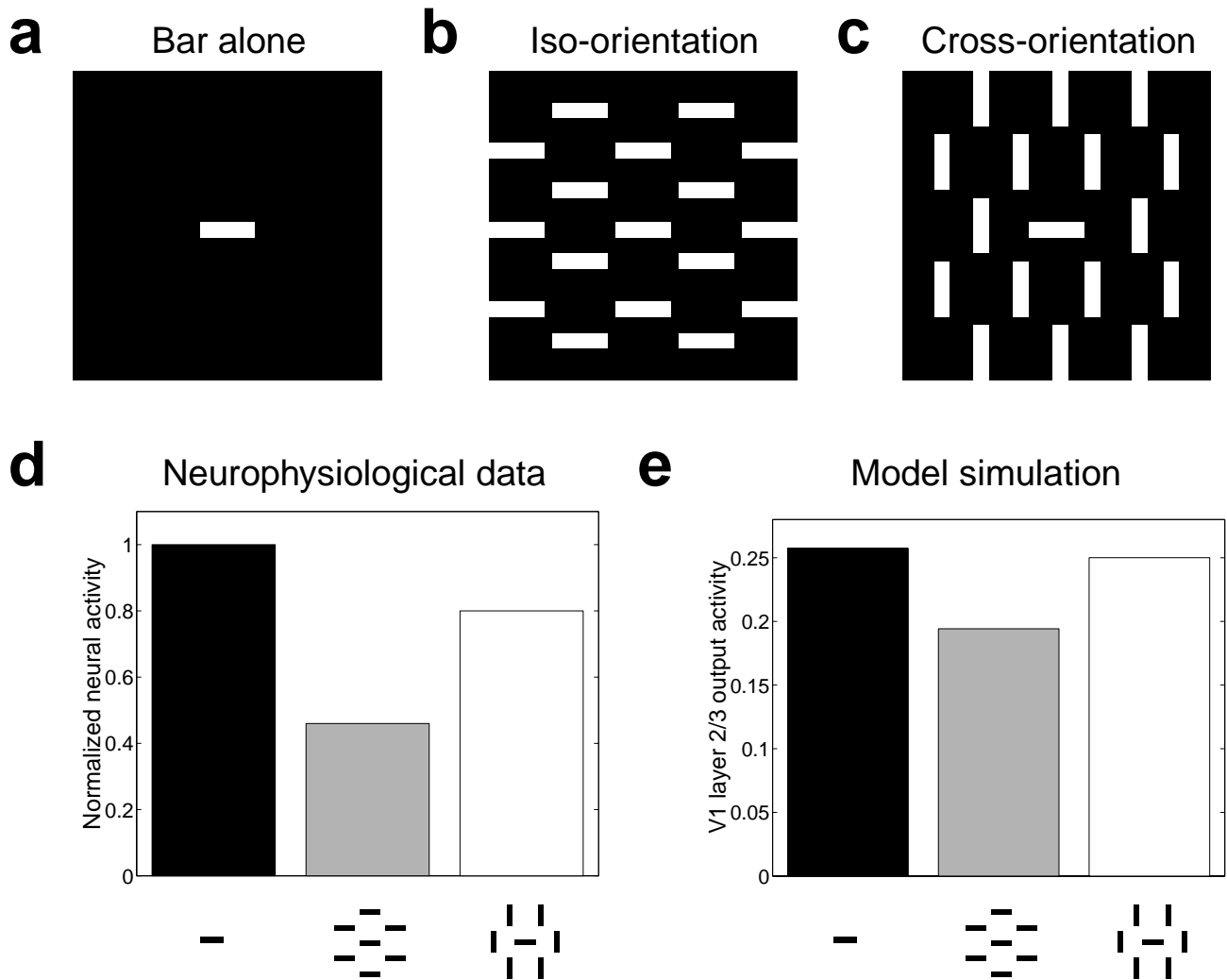

Figure 3: Orientation contrast in V1 and in the neural model. **(a-c):** Stimuli of the sort used by Knierim and Van Essen (1992). The neural responses elicited by an isolated bar are recorded, then compared with responses when the same bar is embedded either in an iso-orientation or cross-orientation texture surround. The images shown here are the actual stimuli that were presented to the model network. **(d):** Neurophysiological data from macaque V1, adapted with permission from Knierim and Van Essen (1992, Fig.10). The icons along the x -axis indicate that the stimuli presented were of the sorts shown in (a), (b) and (c) respectively. It can be seen that both sorts of texture surrounds have a suppressive effect on neural activity, compared to when the bar is presented on its own, but that the orthogonal surround produces less suppression. This is consistent with the perceptual effect that the bar seems to “pop-out” from the orthogonal background but not from the iso-orientation surround. **(e):** Model simulation of the orientation contrast effect. It can be seen here too that both kinds of surround have a net inhibitory effect, with the cross-orientation surround being less suppressive.

areas, namely V1 and V2.

We wish to argue that the ability of the cerebral cortex to implement these different contextual processes *all at once, within the same brain areas* is a more non-trivial functional feat than is widely appreciated. In particular, although the individual tasks of implementing attention and perceptual groupings such as illusory contour grouping may, considered separately, be relatively tractable,

the task of performing both processes at once within the same cortical circuit raises the difficult problem of distinguishing the preattentive from the attentive, the external from the internal: the cortex must be able to tell the difference between activity that conveys information about objects in the environment as opposed to activity that has arisen purely as a result of top-down cortical processing.

For attention, this problem is as follows: top-down attention can enhance the firing of cells which are already active, but if it were to produce above-threshold activity in the absence of any bottom-up retinal input, then the brain would be in danger of hallucinating: activity in V1 and V2 gets passed up to higher areas regardless of how it was caused, and these higher areas would have no means of telling the internally and externally created signals apart. It has, in fact, been elsewhere suggested how a breakdown in this process *can* lead to hallucinations, such as during the positive symptoms of schizophrenia (Grossberg, 2000).

Four possible mechanisms would each seem to provide plausible solutions to this problem. However, we will argue that they all fail, and that a more subtle solution utilizing the laminar architecture of cortex must be used instead.

Firstly, it seems that cortex could ensure that top-down attention on its own never produces above-threshold activity simply by keeping attentional feedback very weak. However, numerous physiological studies show that attention can exert extremely powerful effects in visual cortex, for example modulating the activity of MST cells by 113% (Treue & Maunsell, 1996). As well as being strongly facilitatory, attention can also be strongly suppressive, causing neurons to respond weakly even when their receptive fields contain stimuli that would otherwise elicit optimal responses (Reynolds, Chelazzi, & Desimone, 1999).

A second possibility, often adopted by other computational models, would be to make top-down feedback have a purely multiplicative effect on cortical firing (e.g. Neumann & Sepp, 1999), for instance by having feedback act exclusively on NMDA channels, which open only when the post-synaptic cell is active (e.g. Lumer, Edelman, & Tononi, 1997). This would ensure that only already existing activity could be enhanced. However, this possibility fails to account for the fact mentioned above that attention can be inhibitory, as well as facilitatory. In particular, there is psychophysical and neurophysiological evidence that attention has a facilitatory on-center and suppressive off-surround form (Downing, 1988; Caputo & Guerra, 1998; Mounts, 2000; Smith, Singh, & Greenlee, 2000; Vanduffel, Tootell, & Orban, 2000). Moreover, there is evidence that corticocortical feedback axons act on both non-NMDA and NMDA channels (Cauler & Connors, 1994).

The third possible way of solving the preattentive/attentive interface problem would be if cortex were to enforce the simple rule that only those cells whose CRFs contain visual stimuli should be allowed to be active. However, here the functional difficulties of simultaneously implementing multiple types of contextual processing start to become apparent. This would-be rule is disobeyed by neurons that respond to Kanizsa-type illusory contours. Such neurons give above-threshold responses without having *any* visual stimuli within their CRFs, and are known to exist in V2 (von der Heydt et al., 1984; Peterhans & von der Heydt, 1989) and possibly also in V1 (Nguyen & Lee, 1999). Responses to illusory contours induced by offset gratings have also been found in V1 (Redies, Crook, & Creutzfeldt, 1986; Grosf, Shapley, & Hawken, 1993; Sheth, Sharma, Rao, & Sur, 1996). Although the receptive fields of neurons responding to such stimuli are not completely empty, since they contain line endings, they do not contain any stimuli which have the same orientation as the illusory contour itself.

Thus, cortex is faced with the problem of ensuring that top-down attention can have only a mod-

ulatory effect on bottom-up stimuli, even though groupings like an illusory contour can generate suprathreshold responses at positions that do not receive bottom-up inputs. A fourth possible solution, then, might be simply to ensure that attentional and perceptual grouping are kept firmly separated in cortical processing. However, as mentioned above and illustrated in Figures 4 and 5, there exists neurophysiological and psychophysical evidence that attention actually propagates along both real and illusory contour groupings (He & Nakayama, 1995; Moore et al., 1998; Roelfsema et al., 1998; Roelfsema & Spekreijse, 1999). Thus attention and grouping are intimately linked within the same neural circuitry. That is why we refer to this as an *interface* problem. How, then, are their different, even apparently contradictory, properties generated at an appropriately designed cortical interface?

The experiment by Moore et al. (1998) provided a particularly elegant demonstration that attention can flow along illusory contours. They presented subjects with two “pacmen” stimuli which together induced an illusory Kanizsa rectangle. That is, the two pacmen were separated by retinally unstimulated space, but were perceived as jointly forming a single object in virtue of the illusory contours that connected them. Moore et al. then cued attention to one end of the illusory bar by briefly flashing one of the pacmen, and found that the reaction time to a probe stimulus presented *at the other end* of the bar was improved, showing that the speed-enhancing effect of attention had spread from one side of the illusory contour to the other. In a control condition when the illusory contours were blocked, but all other aspects of the stimuli left the same, the reaction time advantage was now restricted only to the cued pacman inducer. Thus, attention was able to spread across the retinally unstimulated space separating the pacmen if, and only if, they were already joined by a preattentively formed illusory contour grouping. Because attention did not create any new groupings, but merely enhanced ones which the inducers had already formed, its preattentive/attentive interface constraint remained unviolated.

Given, then, that the candidate solutions considered above to the preattentive/attentive interface problem all fail, how does the cortex succeed? The fact that cortex does indeed succeed in solving the problem is evidenced by the co-existence and mutual interaction within V1 and V2 of the two crucial contextual effects of top-down attention and preattentive perceptual grouping. We suggest that the question of how cortex integrates these diverse and seemingly conflicting tasks is one that must be addressed by any descriptively adequate computational model of contextual processing.

We now present a neural model of V1 and V2 which proposes a specific solution to this problem using known properties of cortical laminar design, and which shows in computer simulations how the contextual effects of attention, perceptual grouping and orientation contrast can all be simultaneously implemented. The model builds on and extends previous work presented in Grossberg et al. (1997), Grossberg (1999a) and Grossberg and Raizada (2000).

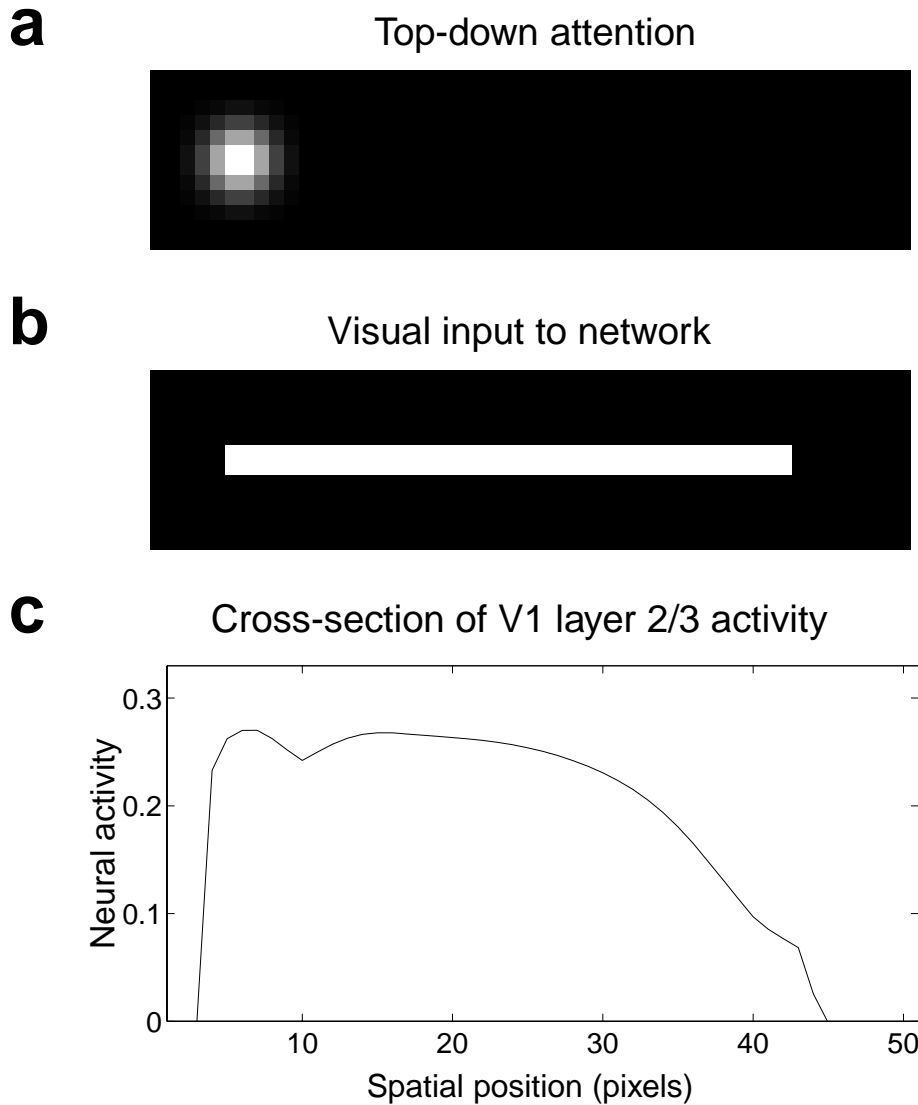

Figure 4: Demonstration of attention flowing along the neural representation of a visual boundary in V1 of the neural model. A similar result was found neurophysiologically by Roelfsema et al. (1998) and Roelfsema and Spekreijse (1999). **(a):** A diffuse Gaussian of top-down attention directed to the end of a line, **(b)**, which was presented as visual input to the model network. **(c):** Cross-section of V1 layer 2/3 activity elicited by the line visual stimulus with the attention directed to the leftmost end. Attention can enter layer 2/3 via two routes, both of which render the attentional enhancement subthreshold via a balance of excitation and inhibition. In one route, attentional feedback passes into layer 6, is folded back up into the modulatory on-center off-surround layer 6 \rightarrow 4 path, and then passes up into layer 2/3. In the second route, attentional feeds back into in V1 layer 1, where it is collected by the apical dendrites of layer 2/3 pyramidal cells and also by the dendrites of inhibitory interneurons with their soma and axons in layer 2/3 but dendrites in layer 1 (Lund & Wu, 1997). It can be seen that attention enhances the end to which it is directed, but that this enhancement flows along the length of the line beyond the range of the attentional Gaussian itself, gradually decaying over distance. This lateral flow is carried by long-range horizontal axons from pyramidals in layer 2/3. The slight dip in neural activity next to the maximally boosted region at the leftmost end is due to the off-surround layer 6 \rightarrow 4 inhibition which attention also induces.

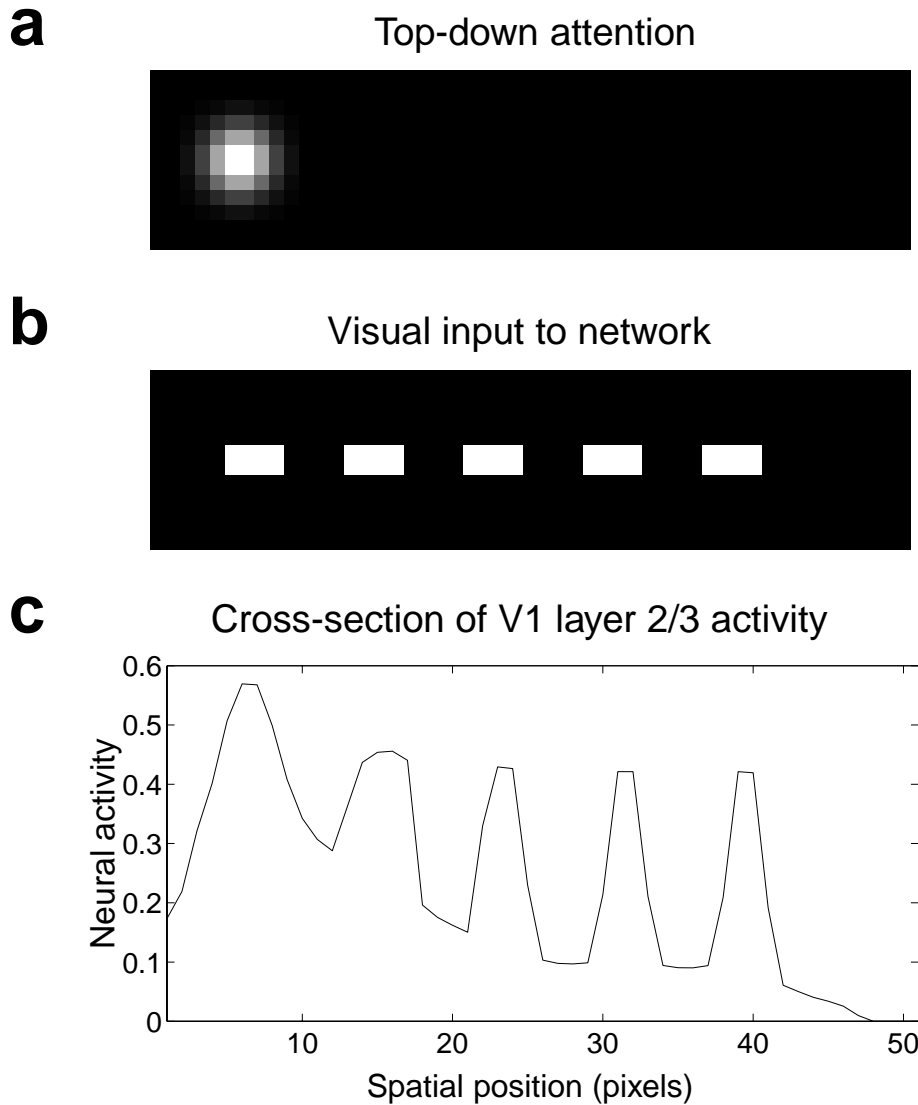

Figure 5: **(a)**: Demonstration of attention flowing along the neural representation of an illusory contour in V1 of the neural model. A similar result was demonstrated psychophysically by Moore et al. (1998). **(a)**: A diffuse Gaussian of top-down attention directed to the end of a dotted line, **(b)**, which was presented as visual input to the model network. **(c)**: Cross-section of V1 layer 2/3 activity elicited by the dotted line visual stimulus and the attention directed to the leftmost end. Note that regions of above-threshold layer 2/3 activity form between the segments of the dotted line, preattentively completing the neural representation of the boundary contour. As in Figure 4, attention flows along the neural representation of the contour, carried by the long-range layer 2/3 horizontal axons linking pyramidal cells which are firing above-threshold. Note that without the preattentive completion of the layer 2/3 boundary representation, attention on its own would have been able only to provide a subthreshold prime to the neurons whose classical receptive fields fall on the gaps in the dotted line. The attentional enhancement extends well beyond the range of the top-down feedback Gaussian itself.

2 Model neural network

The laminar architecture of the present model is constructed out of two fundamental building blocks: an on-center off-surround circuit running from layer 6 to layer 4, and intrinsic horizon-

Connection in model	Functional interpretation	Selected references
LGN → 4	Strong, oriented LGN input	Blasdel and Lund (1983), Ferster et al. (1996, cat)
LGN → 6	LGN input sharpened by 6 → 4 on-center off-surround	Blasdel and Lund (1983)
6 → 4 spiny stellates	Modulatory on-center of the 6 → 4 on-center off-surround	Stratford et al. (1996, cat), Callaway (1998, p.56)
6 → 4 inhibitory interneurons	Off-surround of the 6 → 4 on-center off-surround	McGuire et al. (1984, cat), Ahmed et al. (1997, cat)
4 inhib.int. → 4 inhib.int.	Context-dependent normalization of off-surround inhibition	Ahmed et al. (1997, cat), Tamas et al. (1998, cat)
4 → 2/3 pyramids	Feedforward of stimuli with bottom-up support	Fitzpatrick et al. (1985), Callaway and Wiser (1996)
2/3 pyr. → 2/3 pyr.	Long-range collinear integration along RF axes	Bosking et al. (1997, shrew), Schmidt et al. (1997, cat)
2/3 pyr. → 2/3 inhib.int.	Keep outward grouping subthreshold (Bipole property)	McGuire et al. (1991), Hirsch and Gilbert (1991, cat)
2/3 inhib.int. → 2/3 inhib.int.	Normalize 2/3 inhibition (2-against-1 part of bipole property)	Tamas et al. (1998, cat)
V1 2/3 pyr. → V2 layer 4	Feedforward of V1 boundary groupings into V2	Van Essen et al. (1986), Rockland and Virga (1990)
V1 2/3 pyr. → V2 layer 6	Feedforward V1 groupings into V2 6 → 4 on-center off-surround	Van Essen et al. (1986, p.470)
V1 layer 6 → LGN	Modulatory on-center off-surround feedback	Sillito et al. (1994, cat), Montero (1991, cat)
Feedback routes into V1 layer 6		
V2 layer 6 → V1 layer 1	Standard intercortical laminar feedback (Salin & Bullier, 1995, p.110)	Rockland and Virga (1989)
1 → 6 (within a layer 5 pyr.)	Corticocortical fdbk into 6: Layer 5 pyr., apic.dend. in 1, axon in 6.	Lund and Boothe (1975, Fig.7), Gilbert and Wiesel (1979, cat)
V2 (unknown layer) → V1 layer 6	Direct corticocortical feedback into V1 layer 6	Gattass et al. (1997, Fig.4)
2/3 → 6	Boundary groupings feedback into 6 → 4 on-center off-surround	Blasdel et al. (1985, Fig.13), Kisvarday et al. (1989, Fig.7)
1 → 5	Corticocortical fdbk into 5: Layer 5 pyr. with apic.dend. in 1	Valverde (1985, Fig.24a), Peters and Sethares (1991, p.7)
2/3 → 5	Part of indirect 2/3 → 6 path	Lund and Boothe (1975, Fig.8), Callaway and Wiser (1996)
5 → 6	Continuation of indirect routes into 6, via 5	Blasdel et al. (1985, Fig.17), Kisvarday et al. (1989, Fig.7)

Table 1: All references are to macaque monkey unless otherwise noted.

tal connections in layer 2/3 which perform collinear integration and perceptual grouping. Each of these two sub-circuits has assigned to it a well-defined functional role, and is constructed from model neurons with empirically determined connectivity and physiological properties, as summarised in Table 1. When these building blocks are connected together according to the known anatomy of V1 and V2, as shown in Figure 6, a cortical network is formed whose properties can be understood from the interactions of the functional sub-circuits, but whose behavior is much richer than that of any sub-circuit taken individually.

Attention in the model is mediated by a new mechanism that we call *folded feedback* (Grossberg, 1999a), whereby signals from higher cortical areas, and also the V1 supragranular layers, pass down into V1 layer 6 and are then “folded” back up into the feedforward stream by passing through the layer 6 → 4 on-center off-surround path (Figure 6b), thus giving attention an on-center off-surround form, enhancing attended stimuli and suppressing those that are ignored.

A key prediction of the model is that the on-center of the 6 → 4 path is modulatory (or priming, or subthreshold), consistent with the finding that layer 4 EPSPs elicited by layer 6 stimulation are much weaker than those caused by stimulation of LGN axons or of neighbouring layer 4 sites (Stratford et al., 1996), and also with the fact that binocular layer 6 neurons synapse onto monocular layer 4 cells of both eye types without reducing these cells’ monocularly (Callaway, 1998, p.56). We suggest that the on-center excitation is inhibited down into being modulatory by the overlapping and broader off-surround. Thus, although the center excitation is weak, the suppressive effect of the off-surround inhibition can be strong. Because attentional excitation passes through the 6 → 4 path, it inherits this path’s properties: the attentional on-center is modulatory, able to enhance existing activity but only slightly to elevate neurons’ baseline firing rates in the absence of visual input (Luck,

Chelazzi, Hillyard, & Desimone, 1997), but the off-surround can select strongly against unattended stimuli. The model would still be supported if weak suprathreshold excitatory responses in layer 4 could be created by layer 6 stimulation, as long as these responses meet the crucial condition that they be too weak to cause suprathreshold groupings to occur within the horizontal connections of layer 2/3.

Several routes exist through which feedback from higher cortex can reach V1 layer 6, as shown in Table 1. Figure 6b illustrates the route whereby feedback signals pass into layer 1, where the majority of V2 feedback axons terminate (Rockland & Virga, 1989), and then stimulate the apical dendrites of layer 5 pyramidal cells whose axons send collaterals into layer 6 (Lund & Boothe, 1975; Gilbert & Wiesel, 1979), where the attentional signals are “folded” back up into the 6 → 4 on-center off-surround. Reversible deactivation studies of monkey V2 have shown that feedback from V2 to V1 does indeed have an on-center off-surround form (Bullier, Hupé, James, & Girard, 1996), and moreover that the V1 layer whose activation is most reduced by cutting off V2 feedback is layer 6 (Sandell & Schiller, 1982).

We suggest that the mechanism of folded feedback is also used to help select the final layer 2/3 grouping. If the visual information coming into the brain is unambiguous, then the correct groupings could, in principle, form due to the first incoming wave of activation across layer 2/3 horizontal connections. However, in response to scenes or images with multiple grouping possibilities, the initial groupings that are formed in layer 2/3 may need to be pruned to select those that are correct. Like attentional signals from higher cortex, the groupings which start to form in layer 2/3 also feed back into the 6 → 4 path (Figure 6c), to enhance their own positions in layer 4 via the 6 → 4 on-center, and to suppress input to other groupings via the 6 → 4 off-surround. There exist direct layer 2/3 → 6 connections in macaque V1, as well as indirect routes via layer 5 (Table 1). This competition between layer 2/3 groupings, via layer 2/3 → 6 → 4 → 2/3 feedback, causes the strongest groupings to be selected, while it suppresses weaker groupings, ungrouped distractors, and noise. The interlaminar feedback also binds the cortical layers together into functional columns.

The fact that both attention and perceptual grouping share the properties of enhancing weak stimuli, and of suppressing signals from nearby rival inputs, can thus be parsimoniously explained by the hypothesis that both processes share the 6 → 4 folded feedback path. This laminar architecture also resolves the preattentive-attentive interface problem described above, since despite their shared properties and coexistence side-by-side within V1 and V2, attention and grouping behave quite differently in parts of visual space where there is no bottom-up visual stimulus. Above-threshold boundary groupings *can* form over regions with no bottom-up support, e.g. illusory contours. These groupings form in layer 2/3. However, the only way top-down attentional signals can enter layer 2/3 is by first passing through a pathway in which a balance of overlapping excitation and inhibition damps down the attentional feedback into being subthreshold, or priming. Thus, attention can only modulate layer 2/3, but cannot on its own cause above-threshold activation, and its internal/external problem is thereby resolved.

a**d****b****e****c**

Figure 6: Caption on following page.

Caption to Figure 6. How known cortical connections join the layer 6 \rightarrow 4 and layer 2/3 building blocks to form the entire V1/V2 laminar model. Inhibitory interneurons are shown filled-in black. **(a):** The LGN provides bottom-up activation to layer 4 via two routes. Firstly, it makes a strong connection directly into layer 4. Secondly, LGN axons send collaterals into layer 6, and thereby also activate layer 4 via the 6 \rightarrow 4 on-center off-surround path. Thus, the combined effect of the bottom-up LGN pathways is to stimulate layer 4 via an on-center off-surround, which provides divisive contrast normalization (Grossberg, 1973, 1980; Heeger, 1992) of layer 4 cell responses (see Appendix). **(b):** *Folded feedback* carries attentional signals from higher cortex into layer 4 of V1, via the modulatory 6 \rightarrow 4 path. Corticocortical feedback axons tend preferentially to originate in layer 6 of the higher area and to terminate in the lower cortex’s layer 1 (Salin & Bullier, 1995, p.110), where they can excite the apical dendrites of layer 5 pyramidal cells whose axons send collaterals into layer 6 (the triangle in the figure represents such a layer 5 pyramidal cell). Several other routes through which feedback can pass into V1 layer 6 exist (see Table 1 for references). Having arrived in layer 6, the feedback is then “folded” back up into the feedforward stream by passing through the 6 \rightarrow 4 on-center off-surround path (Bullier et al., 1996). **(c):** Connecting the 6 \rightarrow 4 on-center off-surround to the layer 2/3 grouping circuit: like-oriented layer 4 simple cells with opposite contrast polarities compete (not shown) before generating half-wave rectified outputs that converge onto layer 2/3 complex cells in the column above them. Like attentional signals from higher cortex, groupings which form within layer 2/3 also send activation into the *folded feedback* path, to enhance their own positions in layer 4 beneath them via the 6 \rightarrow 4 on-center, and to suppress input to other groupings via the 6 \rightarrow 4 off-surround. There exist direct layer 2/3 \rightarrow 6 connections in macaque V1, as well as indirect routes via layer 5 (Table 1). **(d):** Top-down corticogeniculate feedback from V1 layer 6 to LGN also has an on-center off-surround anatomy, similar to the 6 \rightarrow 4 path. The on-center feedback selectively enhances LGN cells that are consistent with the activation that they cause (Sillito et al., 1994), and the off-surround contributes to length-sensitive (endstopped) responses that facilitate grouping perpendicular to line ends. **(e):** The entire V1/V2 circuit: V2 repeats the laminar pattern of V1 circuitry, but at a larger spatial scale. In particular, the horizontal layer 2/3 connections have a longer range in V2, allowing above-threshold perceptual groupings between more widely spaced inducing stimuli to form (Amir, Harel, & Malach, 1993). V1 layer 2/3 projects up to V2 layers 6 and 4, just as LGN projects to layers 6 and 4 of V1. Higher cortical areas send feedback into V2 which ultimately reaches layer 6, just as V2 feedback acts on layer 6 of V1 (Sandell & Schiller, 1982). Feedback paths from higher cortical areas straight into V1 (not shown) can complement and enhance feedback from V2 into V1.

In the earlier version of this model presented in Grossberg and Raizada (2000), the only pathway via which attention could enter layer 2/3 was the folded-feedback layer 6 \rightarrow 4 \rightarrow 2/3 circuit described above. Since the majority of feedback axons from higher cortical areas terminate in V1 layer 1 (Rockland & Virga, 1989), we also discussed the possibility that attentional signals may modulate layer 2/3 more directly by stimulating the layer 1 apical dendrites of layer 2/3 pyramidal cells. Lund and Wu (1997) have shown that there exist inhibitory interneurons in layer 2/3 macaque V1 which also have dendrites in layer 1. Hence, we suggested that there may also exist a balance of excitation and inhibition keeping this direct attentional path into layer 2/3 modulatory, or subthreshold, just as the layer 6 \rightarrow 4 off-surround overlaps with and balances 6 \rightarrow 4 the on-center. Going beyond this earlier paper, we have now implemented these connections in the present simulations (see Equations 20 and 21). As will be discussed in Section 3.3 below, the extended model incorporating these anatomical connections is still able to keep top-down feedback’s facilitatory effect within layer 2/3 purely modulatory.

The notion of activity being subthreshold, or modulatory, is given a simple instantiation in the model’s equations: layer 2/3 activity below a fixed value, Γ , produces no output from the cells in that layer. When the input activity starts to exceed Γ , the output starts to climb from zero at the same rate, as described in Equation 13. In both V1 and V2, Γ was fixed at 0.2 for all the simulations performed. Because this layer 2/3 signal function is continuous, and gives the output the same gain as the input, the behavior of the network changes continuously and predictably if Γ is changed: smaller values would tend to allow stronger layer 2/3 bipole groupings to form, for

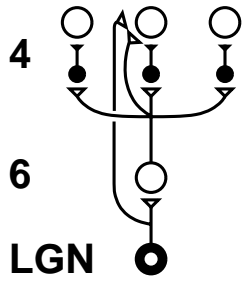
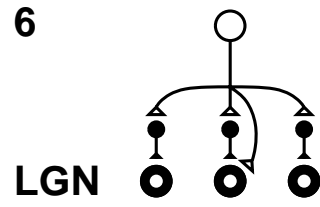
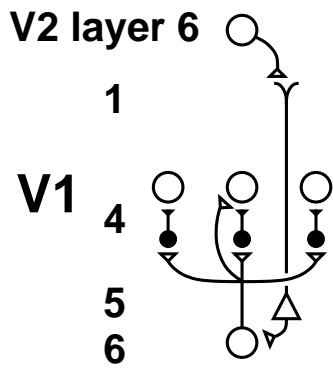
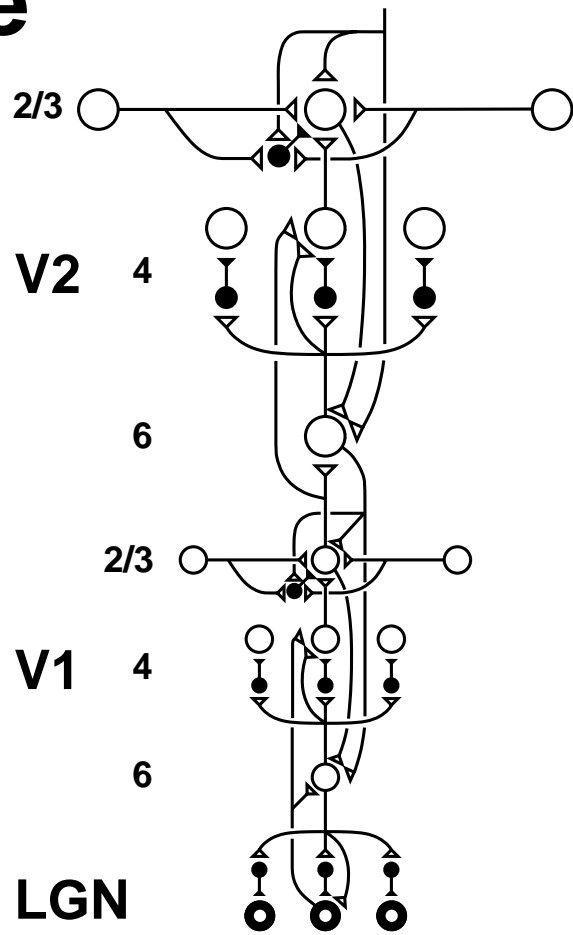
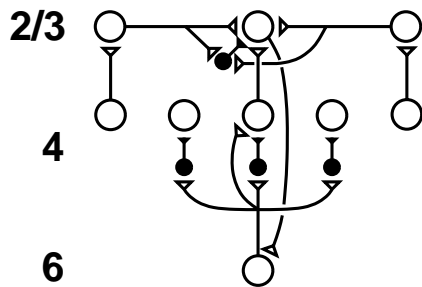
example allowing V1 groupings to bridge over slightly larger visual gaps than otherwise. Larger values would tend slightly to weaken the groupings, and to mean that larger top-down attention signals would be required to influence the groupings that do form.

We also extend the network dynamics of the model presented in Grossberg and Raizada (2000) in another respect. In that study, we showed how the model could simulate the finding by Polat et al. (1998) that neurons in cat V1 responding to a low-contrast target Gabor stimulus are net facilitated by the presence of collinear flanking Gabor patches, but when the target is high-contrast, the effect of the flankers “crosses over” into being net inhibitory. The simulation in the Grossberg and Raizada (2000) paper showed that a long-range range V2 grouping between the flanking elements fed back a subthreshold prime to the V1 location of the central target Gabor, facilitating it by raising it above threshold at low-contrasts. However, shunting $6 \rightarrow 4$ inhibition from the flankers also had a divisive effect on neural responses to the target, lowering their gain and causing the net effect of the flankers to be suppressive at high-target contrasts. Thus, this simulation showed how contrast-dependent perceptual grouping can emerge as a result of network behavior, without needing to take into account possible differential effects of contrast on individual excitatory and inhibitory neurons.

Substantial neurophysiological evidence exists, however, showing that at high stimulus contrasts, inhibition starts to predominate over excitation as a combined result of several diverse factors: inhibitory interneurons have higher gains than excitatory pyramidal cells at high contrast (McCormick, Connors, Lighthall, & Prince, 1985), inhibitory synapses depress less than excitatory synapses (Varela, Song, Turrigiano, & Nelson, 1999), with synapses from inhibitory interneurons onto pyramidals in fact actively facilitating (Thomson, 1997; Markram, Wang, & Tsodyks, 1998; Reyes, Lujan, Rozov, Burnashev, Somogyi, & Sakmann, 1998). This complex mixture of pre- and post-synaptic factors cannot be completely captured without greatly complicating the existing model; we approximate the total net effect on inhibition by passing the population inhibitory activity through a sigmoidal signal function, as shown in Eqs. 16 and 17. This signal function starts off at low values, and then rapidly increases as higher contrast stimuli cause greater levels of inhibitory activation. Since the network pyramidals gradually saturate at increasing contrasts, the net effect is for inhibition to start to predominate (c.f. Grossberg, 1970; Stemmler et al., 1995; Somers et al., 1998; Grossberg & Kelly, 1999). By extending the previous model in this way, the model can capture an even wide-ranger of contrast-sensitive grouping effects. An example is the simulation of recent data from Kapadia et al. (1998) presented in Section 3.4 below.

3 Results

The model presented here captures several aspects of visual contextual processing. The following simulations and explanations illustrate how the laminar architecture of cortex brings about this behavior.

3.1 Attention has a greater effect on low-contrast stimuli

As was remarked in the introduction, top-down attention is needed most when a visual target is of low salience due to being surrounded by distractors, or being of low contrast. It would therefore be functionally advantageous for attention to provide a strong boost to low contrast targets, but to have a relatively weaker effect at high contrasts. This is exactly what was observed in the recent

behavioral study of macaque monkeys by De Weerd et al. (1999). The monkeys' task was to discriminate the orientation of a variable-contrast grating patch which was surrounded by distractors. Stimuli of this sort were presented to the model network, as shown in Figure 2a. De Weerd et al. placed the stimuli in either an unlesioned visual quadrant, or ones in which lesions had been made to cortical areas V4 or TEO, both of which are known to play important roles in visual attention. Their finding, illustrated in Figure 2c, was that the absence of these attentional regions severely impaired the monkeys' performance when the target grating was low contrast, but had relatively little effect when the target was high contrast. As can be seen from Figure 2d, the model simulation produces very similar behavior. Here, the "behavioral threshold" of the network is simply operationalized as the reciprocal of the activity of the V1 layer 2/3 cells which respond to vertical orientations. Because the model only simulates V1 and V2, rather than higher areas such as prefrontal cortex which presumably control the behavioral responses made by the macaque, the network does not literally have a "behavioral threshold". However, the layer 2/3 neurons which respond to vertical orientations are the cells which would pass forward information about the grating's orientation to higher areas. The greater the activity of these cells, the stronger and hence the more discriminable is the information which is passed forward. Since high discriminability would result in a low behavioral threshold, and *vice versa*, the simplest way of embodying this process in an equation is to take the reciprocal. Instead of having to lesion higher cortical areas, we are able simply to turn attention on and off in the model; attention is implemented as a diffuse Gaussian of unoriented cortical feedback directed to the target's location.

In the model, attention aids discrimination by boosting the neural representation of the target through the layer 6 \rightarrow 4 on-center, and also via the direct attentional projection into layer 2/3. It also suppresses the distractors, which fall into attention's layer 6 \rightarrow 4 off-surround. However, these facts alone are not enough to explain why attention facilitates the lower contrast targets more than the high contrast ones. This behavior follows from two closely related network phenomena: shunting inhibition and neural saturation. High-contrast stimuli induce strong 6 \rightarrow 4 on-center excitation at their own locations, but also bring with them divisive shunting inhibition from the overlapping 6 \rightarrow 4 off-surround, thereby reducing their own contrast gain. Hence, lower contrast stimuli have higher gain and can therefore be boosted more by attention. Similarly, the simple fact of neural saturation means that cells which are firing far below their maximal rate can be significantly boosted by attention, but cells which are pushed close to saturation by high contrast stimuli cannot.

3.2 Orientation contrast

Another important contextual effect exhibited by the model network is orientation contrast, in which stimuli which are embedded in orthogonally oriented texture surrounds are seen to "pop-out", whereas stimuli which are in iso-orientation surrounds do not (Nothdurft, 1991; Knierim & Van Essen, 1992; Sillito et al., 1995; Nothdurft et al., 1999). This perceptual effect is reflected in the activity of V1 neurons: although both iso- and cross-orientation surrounds have a net suppressive effect on the neural response to an isolated bar, the cross-orientation surround is significantly less suppressive (Knierim & Van Essen, 1992, data shown in Figure 3d). Examples of the types of stimuli used by Knierim & Van Essen are shown in Figure 3a-c. These images were in fact presented as stimuli to the model network. As shown in Figure 3e, model V1 neurons exhibit the same qualitative pattern of behavior. The explanation for this is simply that in the model, layer 6 \rightarrow 4 iso-orientation off-surround inhibition is stronger than the cross-orientation inhibition. The key question is: how did the inhibition come to be that way? The relative strengths of the iso- and cross-

orientation inhibitory projective fields were not specified by hand, but instead were self-organized in the developmental laminar model of Grossberg and Williamson (2000) which used the same laminar architecture as the present model, but without the corticocortical attentional connections. In the course of that model's self-organizing development, the synapses tracked the statistics of visual inputs which were presented to the network. These inputs contained visual structure, in particular straight edges, which caused iso-orientation correlations between neurons positioned along the length of the edge. The inhibitory synapses tracked these iso-orientation correlations, with the result that the the iso-orientation inhibition grew stronger than that for cross-orientations.

3.3 Attention flows along real and illusory contours

As remarked in introduction, the ability of attention to flow along real and illusory contours places important constraints on visual cortical processing. Attention must be able to flow along contour groupings which are already preattentively active, but cannot cause above-threshold activity on its own. The fact that attention does indeed flow along groupings is no mere epiphenomenon, but is the key mechanism uniting spatial and object-based attention in early visual cortex. In particular, attention can thereby selectively enhance an entire object by propagating along its boundaries.

Grossberg and Raizada (2000) simulated the study by Roelfsema et al. (1998), including the delayed time-course of attentional enhancement, caused by the time needed for attention to propagate along the representation of the curve. Here we show in more detail the spatial spread of attention along a real or illusory curve, illustrated in Figures 4 and 5. In both cases, a Gaussian of diffuse attentional feedback directed to one end of a line stimulus causes excitation that does not just boost the directly attended location, but also spreads along some of the length of the line, even when the line is physically discontinuous but perceived as forming a collinear grouping (Figure 5).

This lateral spread of attentional excitation is carried by the long-range horizontal connections in layer 2/3 of V1 and V2. As described in Section 3 above, there exist two routes by which attention can get into layer 2/3. The main route is that attention passes into layer 6, is then folded back up into the layer 6 \rightarrow 4 on-center off-surround path, where the balance between the on-center excitation and the overlapping off-surround inhibition ensures that the attentional enhancement which can then feed on into layer 2/3 is purely subthreshold. The second route is the direct attentional connection into layer 2/3, illustrated in Figure 6e and described in Equations 20 and 21. The model layer 2/3 contains inhibitory interneurons as well as excitatory pyramidal cells, in order to control the formation of groupings through layer 2/3 horizontal connections, and the attentional feedback synapses onto both of them, again providing a balance of suppressive and facilitatory forces which ensures that attentional enhancement remains subthreshold. Although this subthreshold signal would on its own be unable fully to activate layer 2/3, it can nonetheless boost preattentively formed collinear groupings which form along the line stimuli, and, in the case of the dotted line, bridge over the gaps of retinally unstimulated space. Note that in both cases, the attentional enhancement gradually declines with distance from the attention focus, due to decay of neural activity. The rate of fall-off with distance is smaller in V2 than in V1, due to the longer-range layer 2/3 horizontal connections found in the higher area (Amir et al., 1993).

3.4 Contrast-sensitive grouping and inhibition

Contextual effects can be either facilitatory or inhibitory, depending on stimulus contrast. In particular, the effect of collinear flankers on a target can "crossover" from being net excitatory at low

contrasts to being net suppressive at high-contrasts, either when the central target alone varies in contrast (Polat et al., 1998), or when the target and flankers all vary in contrast together. As discussed in Section 3 above, several pre- and post-synaptic factors may contribute to the predominance of inhibition over excitation at higher stimulus contrasts, although network-level effects alone can be sufficient to account for the Polat et al. (1998) data, as shown in our previous paper (Grossberg & Raizada, 2000).

Figure 1 shows a crossover effect using three bars of equal contrast, as demonstrated experimentally by Kapadia et al. (1998). The flanking bars exert both excitatory and inhibitory effects on the central target. At low contrasts, the layer 6 \rightarrow 4 inhibitory sigmoidal signal function still takes low values, and inhibition is weaker than the collinear layer 2/3 excitation, giving a net facilitatory effect (Figure 1b). At higher stimulus contrasts, the total amount of inhibition starts to fall into the rapidly growing section of the sigmoidal inhibitory signal function, allowing inhibition from the flankers to overwhelm the excitation that they also supply, making their net effect suppressive (Figure 1c).

4 Discussion

The neural model presented here shows how visual cortex can implement several types of contextual processing at once, and also allow them to interact. In doing so, it builds upon and extends the simulations presented in Grossberg et al. (1997), Grossberg and Raizada (2000), and Grossberg and Williamson (2000). Moreover, the model proposes specific functional roles for known laminar circuits to carry out the contextual processing, and suggests how attention and perceptual grouping can interact within this laminar circuitry to solve the preattentive/attentive interface problem.

As far as we are aware, no other existing model meets the challenge of this problem by attempting to emulate cortex's ability to perform attention and perceptual grouping simultaneously. Whereas the functional importance of top-down attention is clear, the formation of illusory contours may at first sight appear to be an almost epiphenomenal consequence of the seemingly more fundamental process of collinear facilitation. However, illusory contours can perform a crucial task which mere facilitation cannot: they can actively close incomplete boundaries, a process that requires that cells with unstimulated CRFs can nonetheless become active. This boundary closure can guide surface reconstruction, complete boundaries over visual gaps caused by the blind-spot and retinal veins, and also provide enhanced information for the recognition of partially occluded objects (Grossberg, 1994). Several other models of collinear grouping in V1 produce facilitation but not illusory contours, and hence are unable to capture this important aspect of cortical processing (Stemmler et al., 1995; Li, 1998; Somers et al., 1998; Yen & Finkel, 1998). Those models which do implement illusory contours either leave out any consideration top-down cortical feedback (Williams & Jacobs, 1997; Heitger, von der Heydt, Peterhans, Rosenthaler, & Kubler, 1998), fail to capture the on-center off-surround form of attention by treating top-down feedback as having a purely excitatory multiplicative effect (Neumann & Sepp, 1999), or treat "reentrant" feedback signals from higher areas "as if they were signals from real contours in the periphery entering via $4C\alpha$ " (Finkel & Edelman, 1989, p.3197), thereby creating the risk of perceptual hallucinations. Conversely, many models of top-down feedback in visual processing do not implement perceptual grouping (e.g. Harth, Unnikrishnan, & Pandya, 1987; Mumford, 1992; Olshausen, Anderson, & Van Essen, 1993; Ullman, 1995; Tsotsos, Culhane, Wai, Lai, Davis, & Nuflo, 1995; Usher & Niebur, 1996; Rao & Ballard, 1999), therefore leaving untouched what we suggest are crucial design constraints which shape the functional laminar architecture of cortex.

In our previous paper (Grossberg & Raizada, 2000), we presented simulations of the earlier version of this model, which differed from the present one only in lacking the direct attentional connections into layer 2/3, and the layer 6 \rightarrow 4 inhibitory signal function. Three types of behavior were simulated in the earlier paper: attention protecting a target from the suppressive effect of flankers (Reynolds et al., 1999), the time-course of attention flow along a curve (Roelfsema et al., 1998), and contrast-sensitive perceptual grouping of Gabor patches (Polat et al., 1998). As can be seen from the simulations presented in the current paper, these properties still hold in the extended version of the model, although here they are applied to different, but related, sets of stimuli. Thus, the new extensions to the model maintain and extend its previous qualitative patterns of behavior, although the exact quantitative behavior is not identical, due to the addition of the new circuitry.

These modeling results also bear upon other issues concerning cortical coding. For example, in response to unambiguous visual information, a boundary grouping can start to form very rapidly in response to a feedforward sweep of signal from layer 4 to layer 2/3. Thus the existence of cortical feedback does not preclude fast cortical processing (Thorpe, Fize, & Marlot, 1996). Intracortical feedback is predicted to become increasingly important when multiple groupings of the image or scene are possible. Even here, the model's selection of a final grouping can often converge within one or at most a few feedback cycles between layers 4 \rightarrow 2/3 \rightarrow 6 \rightarrow 4. Intercortical feedback may be needed when attention must select some cue combinations over others, based on higher-order constraints. The model shows how very high-order constraints can, in principle, modulate even low-order feature detectors by propagating across multiple cortical regions via their layers 6, without ever fully activating their groupings in layer 2/3. An open experimental question concerns whether and how such a propagating priming effect is attenuated as a function of the number of cortical regions that are traversed. It has also been simulated how these grouping and attentional circuits may rapidly synchronize, even generating fast synchronizing oscillations under some conditions (Grossberg & Somers, 1991; Grossberg & Grunewald, 1997)

All of these statements require qualification, however. For example, the context-dependent persistence of previously grouped images may interfere with the synchrony of subsequent groupings, as illustrated by the model of Francis, Grossberg, and Mingolla (1994). Also, the fact that attention-induced increases in firing rate can propagate along perceptual groupings (see Figures 4 and 5), thereby selectively enhancing object representations, shows that synchronous activation of an object by attention is not necessary in all cases (Roelfsema et al., 1998). Finally, one needs to emphasize that all the explanations and simulations presented above, and those in earlier articles about this evolving cortical model, concern only processing of visual boundaries within the interblob stream of visual cortex, as opposed to the processing of surface brightness and color within the blob stream. Boundary groupings within the interblob stream are predicted, in the absence of surface featural information, to be invisible, or amodal. Hence, all of the results in this series of articles strictly concern only the salience of boundary groupings, not the perception of the surfaces which these boundaries enclose. Visibility is predicted to be a property of surface representations within the blob stream, with these surfaces arising due to the filling-in of brightness and color within closed boundary groupings formed in the interblob stream (Grossberg, 1994). Whereas contour salience and visibility often covary, this is not always the case: for example, Glass patterns (Glass, 1969) contain highly salient concentric contour groupings, but do not induce any brightness differences that would cause bright Ehrenstein-like circular surfaces to be visible. Another limitation of the present model is that it does not describe how transient responses to changing or moving stimuli can rapidly attract visual attention. One major pathway for this mechanism is likely to be the "where" dorsal cortical stream. Recent models of motion processing clarify the key role of these transient responses (Chey, Grossberg, & Mingolla, 1997, 1998; Baloch, Grossberg, Mingolla, & Nogueira, 1999), and also how

they can attract visual attention (Grossberg, 1998).

Several studies providing important data on grouping and also attention in V1 have recently been carried out by Charles Gilbert and colleagues. In particular, Kapadia et al. (1998) used oriented line stimuli of the sort shown in Figure 1a to investigate the spatial arrangement of contextual facilitation and inhibition induced by flanking lines which were of the same orientation as the target. They found that the flankers were facilitatory when they were placed to be approximately collinear with the target line, but were inhibitory when they were located to its sides. In the present model, stimuli induce a pool of layer 6 \rightarrow 4 off-surround inhibition around them which extends in all directions, as shown in Figure 7, and also induce a more strongly anisotropic region of layer 2/3 facilitation, oriented primarily collinearly with the stimulus itself (Figure 8). These regions of facilitation and inhibition spatially overlap. However, the collinear excitation at the ends of an oriented line can be strong enough to overwhelm the inhibition which is also generated there, giving a net facilitatory effect, especially at low stimulus contrasts. Thus, we suggest that the existence of a net excitatory effect at locations collinear with a line ending does not imply that the inhibitory off-surround is restricted to being present only by the line's sides. In fact, the existence of off-surround inhibition at a line ending can be very useful functionally, for example in generating end-cuts (Grossberg & Mingolla, 1985).

Ito and Gilbert (1999) examined the interaction of top-down attention and collinear facilitation in V1 of macaque monkeys which were performing a brightness comparison task. Although this study is pioneering in investigating the interaction of these visual processes, we have not simulated their neural data here since their results were not consistent across the two monkeys from which recordings were made. In one monkey, focal attention directed to a target line was found to increase the facilitatory effect upon that line of a collinear flanker. In the other monkey, the opposite effect was found. Several factors might contribute to this discrepancy. As remarked by Ito and Gilbert themselves, the monkeys had undergone different amounts of training. Another possibility is that the requirements of the behavioral task were not well-suited for probing the most commonly needed functions of attention and grouping: as we argued in Section 1, these processes are needed most when a visual target is weak or low-contrast, and hence hard to detect. In such circumstances, one would expect both processes, and their interaction, to be facilitatory. However, in the Ito & Gilbert study, the target was bright and easily detectable, and the task was to discriminate its brightness as accurately as possible. Thus, a simple net facilitation of neural activity could actually hinder the monkey's brightness judgment. This conflict between the specific task demands and the most common ecological uses of attention and grouping may partially account for the differences between the monkeys. In the present model, a possible mechanism which might underlie such a difference would be the width of the attentional focus directed at the target line. If the focus is narrow, it will enhance the target, but attention's off-surround will actively suppress the collinear flanker, and attention will tend to reduce the flanker's facilitatory effect. If the focus is slightly wider, the attentional on-center will fall on both target and flanker, and the facilitatory effect of the collinear grouping will be enhanced.

Because the present model assigns specific functional roles to many aspects of cortical laminar circuitry, many testable predictions can be derived from it. Several such predictions are presented in the conclusion of Grossberg and Raizada (2000). The simulations presented here extend and broaden the scope of the model, and also generate new predictions over and above those already presented. Perhaps the most directly testable of these concern the spread of attention along illusory as well as real contour groupings (see Figures 4 and 5). We suggest that there should exist measurable neurophysiological correlates of such flow, in particular in layer 2/3 of V2 and possibly also of V1. This could be tested by replicating the Roelfsema et al. (1998) study, but having the mon-

keys trace curves made of dashed instead of solid lines. V2 neurons lying along the empty parts of the dashed lines should fire as a result of collinear grouping (von der Heydt et al., 1984), and we predict that attention to the traced curve should be able to enhance such firing, just as in the case where the complete contour is physically present. It also follows from the model that attentional enhancement should be more pronounced for low contrast stimuli (see the simulation of the De Weerd et al. (1999) data in Figure 2). Thus, using low contrast dashed lines should make it easier to observe the predicted attentional effect.

Appendix: Model equations

Retina

The model retina has at each position (i, j) both an ON-cell, u_{ij}^+ , whose receptive field has the form of a narrow on-center and a Gaussian off-surround, and an OFF-cell, u_{ij}^- , with a narrow off-center and a Gaussian on-surround (Schiller, 1992). As is observed *in vivo*, these ON and OFF cells feed forward into ON and OFF channels of the LGN, and enable the network to respond both to light increments and to light decrements. The retinal cell activities caused by constant visual inputs I have the equilibrium values:

$$u_{ij}^+ = I_{ij} - \sum_{pq} G_{pq}(i, j, \sigma_1) I_{pq}, \quad (1)$$

and

$$u_{ij}^- = -I_{ij} + \sum_{pq} G_{pq}(i, j, \sigma_1) I_{pq}, \quad (2)$$

where $G_{pq}(i, j, \sigma)$ is a 2-dimensional Gaussian kernel, given by:

$$G_{pq}(i, j, \sigma) = \frac{1}{2\pi\sigma^2} \exp\left(-\frac{1}{2\sigma^2}((p-i)^2 + (q-j)^2)\right). \quad (3)$$

The Gaussian width parameter was set to: $\sigma_1 = 1$.

Lateral Geniculate Nucleus

The ON and OFF cells of the LGN, v_{ij}^+ and v_{ij}^- , are excited by the half-wave rectified ON and OFF cells of the retina, respectively. These retinal inputs are also multiplicatively gain-controlled by on-center off-surround feedback from V1 layer 6 (Sillito et al., 1994; Gove et al., 1995; Przybyszewski et al., 1998). Layer 6 cells, x_{ijk} , at position (i, j) and of all orientations, k , send on-center excitation, A_{ij} , to LGN neurons at the same position, and send a 2-dimensional Gaussian spread of off-surround inhibition, B_{ij} , to LGN neurons at the same and nearby positions, as shown in Figure 6d:

$$\frac{1}{\delta_v} \frac{d}{dt} v_{ij}^+ = -v_{ij}^+ + (1 - v_{ij}^+) [u_{ij}^+]^+ (1 + A_{ij}) - (1 + v_{ij}^+) B_{ij}, \quad (4)$$

and

$$\frac{1}{\delta_v} \frac{d}{dt} v_{ij}^- = -v_{ij}^- + (1 - v_{ij}^-) [u_{ij}^-]^+ (1 + A_{ij}) - (1 + v_{ij}^-) B_{ij}. \quad (5)$$

In equations (4) and (5), the Layer 6 on-center off-surround feedback terms, A_{ij} and B_{ij} , are given by:

$$A_{ij} = C_1 \sum_k x_{ijk}, \quad (6)$$

and

$$B_{ij} = C_2 \sum_{pqk} G_{pq}(i, j, \sigma_1) x_{ijk}, \quad (7)$$

where the off-surround Gaussian, $G_{pq}(i, j, \sigma_1)$ is defined by equation (4), and the notation $[u_{ij}^+]^+$ signifies half-wave rectification, $[u_{ij}^+]^+ = \max(u_{ij}^+, 0)$. The parameters for the LGN were: $\delta_v = 1.25$, $C_1 = 1.5$, $C_2 = 0.075$.

LGN inputs to cortical simple cells

At each position, (i, j) , and for each orientation, k , the model has a even-symmetric simple cell with two parallel elongated parts: an ON subregion, R_{ijk} , which receives excitation from LGN ON cells beneath it and is inhibited by LGN OFF cells at the same position; and an OFF subregion, L_{ijk} , which has the converse relation to the LGN channels (Reid & Alonso, 1995; Hirsch et al., 1998). This physiology is embodied in the equation for the ON subregion by subtracting the half-wave rectified LGN OFF channel, $[v_{pq}^-]^+$, from the rectified ON channel, $[v_{pq}^+]^+$, and convolving the result with the positive lobe of a Difference-of-Offset-Gaussians (DOOG) kernel, $[D_{pqij}^{(k)}]^+$, which has the simple cell subfield's characteristic oriented elongated shape. The OFF subregion, L_{ijk} , is similarly constructed:

$$R_{ijk} = \sum_{pq} ([v_{pq}^+]^+ - [v_{pq}^-]^+) [D_{pqij}^{(k)}]^+, \quad (8)$$

and

$$L_{ijk} = \sum_{pq} ([v_{pq}^-]^+ - [v_{pq}^+]^+) [-D_{pqij}^{(k)}]^+, \quad (9)$$

where the oriented DOOG filter $D_{pqij}^{(k)}$ is given by:

$$D_{pqij}^{(k)} = G_{pq}(i - \delta \cos \theta, j - \delta \sin \theta, \sigma_2) - G_{pq}(i + \delta \cos \theta, j + \delta \sin \theta, \sigma_2), \quad (10)$$

with $\delta = \sigma_2/2$ and $\theta = \pi(k - 1)/K$, where k ranges from 1 to $2K$, K being the total number of orientations. For simplicity, the number of orientations was set to $K = 2$ (vertical and horizontal) in the present simulations. The width parameter for the DOOG filter was $\sigma_2 = 0.5$.

At an oriented contrast edge, a suitably oriented simple cell of the correct polarity will have its ON subfield stimulated by a luminance increment and its OFF subfield stimulated by an equal but opposite decrement. The optimal nature of this stimulus is embodied in the following equation, in which simple cell activity is the rectified sum of the activities of each subfield, minus their difference:

$$S_{ijk} = \gamma[R_{ijk} + L_{ijk} - |R_{ijk} - L_{ijk}|]^+. \quad (11)$$

Recent physiological studies have confirmed that layer 4 simple cells that are sensitive to opposite contrast polarities pool their outputs at layer 2/3 complex cells (Alonso & Martinez, 1998). In order to make the simulations manageable, cells in layers 6 and 4 were implemented with their simple cell inputs already pooled, thus halving the number of cells. Since the present model is not used to simulate any polarity-specific interactions in these layers, this simplification leaves the output unaffected. Thus, the polarity-pooled input from LGN to cortical layers 6 and 4 was calculated as the term C_{ijk} , which pools over opposite-polarity simple cells:

$$C_{ijk} = S_{ijk} + S_{ij(k+K)}, \quad (12)$$

where k ranges from 1 to K . The parameter for the simple cell responses, was set to $\gamma = 10$.

Layer 6 cells

V1 layer 6 cells, x_{ijk} , receive input from the LGN (Blasdel & Lund, 1983), which, as described above, is represented by the contrast-polarity pooled oriented input, C_{ijk} . They also receive two types of *folded-feedback* excitation. The first type is intracortical feedback from above-threshold pyramidal cells in V1 layer 2/3, z_{ijk} , as shown in Figure 6c (Blasdel et al., 1985; Kisvarday et al., 1989). These are passed through a thresholding signal function, F , given by:

$$F(z_{ijk}, \Gamma) = \max(z_{ijk} - \Gamma, 0), \quad (13)$$

where Γ is the threshold value. The second type of folded feedback is intercortical attentional feedback from V2, x_{ijk}^{V2} (Sandell & Schiller, 1982), originating in V2 layer 6 (Rockland & Virga, 1989), as shown in Figure 6b. The feedback axons from V2 terminate predominantly in V1 layer 1 (Rockland, 1994). There exist several routes through which these layer 1 signals can pass down into layer 6, notably via the layer 1 apical dendritic tufts of layer 5 pyramidal cells with axon collaterals in 6 (Lund and Boothe (1975), Gilbert and Wiesel (1979). See also Table 1). These paths are not explicitly implemented in the present model.

In attentional simulations, an additional term, att , is added to the excitatory channel, implementing a 2-dimensional Gaussian spread of attentional signals, centered on the attended location and exciting all orientations equally. This attentional term is applied both to V1 and to V2. In the non-attentional simulations, $att = 0$. Thus:

$$\frac{1}{\delta_C} \frac{d}{dt} x_{ijk} = -x_{ijk} + (1 - x_{ijk}) \left(\alpha C_{ijk} + \phi F(z_{ijk}, \Gamma) + V_{21} x_{ijk}^{V_2} + att \right). \quad (14)$$

This equation was solved at equilibrium, giving:

$$x_{ijk} = \frac{\alpha C_{ijk} + \phi F(z_{ijk}, \Gamma) + V_{21} x_{ijk}^{V_2} + att}{1 + \alpha C_{ijk} + \phi F(z_{ijk}, \Gamma) + V_{21} x_{ijk}^{V_2} + att}. \quad (15)$$

The equations for layer 6 of V2 are identical to those just given for V1, with the exception that the V2 \rightarrow V1 feedback term, $V_{21} x_{ijk}^{V_2}$, is now absent. Parameters for the terms in the layer 6 equation were: $\delta_C = 0.25$, $\alpha = 0.5$, $\phi = 2.0$, $\Gamma = 0.2$, $V_{21} = 1$.

Layer 4 activity

Model spiny stellate cells in layer 4, y_{ijk} , as well as receiving the contrast-polarity pooled oriented input, C_{ijk} , described above, also receive on-center off-surround input from layer 6, as shown in Figure 6a. The on-center consists of excitatory connections from layer 6, x_{ijk} , to layer 4 spiny stellates at the same position and of the same orientation (Stratford et al., 1996; Wiser & Callaway, 1997). The off-surround input is caused by medium-range projections from layer 6 onto layer 4 inhibitory interneurons (McGuire et al., 1984; Ahmed et al., 1997). The spatial distribution and strength of these connections are determined by a 2-dimensional kernel, W_{pqrijk}^+ , which is in the present model a linearly scaled version of a self-organized 6-to-4 inhibitory kernel grown in the developmental study by Grossberg and Williamson (2000) using the same network architecture, but without the corticocortical feedback connections. The spatial distribution of this kernel, which is approximately Gaussian, is shown in Figure 7a. Therefore, the distribution of the off-surround inhibition in the present model is not hand-crafted by an algebraic equation, but is instead the product of a self-organized equilibrium reached by the same network architecture in response to naturally structured visual inputs.

As remarked in Section 3 above, the version of the model presented here extends that of Grossberg and Raizada (2000) by considering the complex mixture of pre- and post-synaptic factors which collectively contribute to the tendency for the total amount of inhibition to predominate over excitation at high stimulus contrasts. We approximate the total net effect of these factors by passing the population inhibitory activity through a sigmoidal signal function, f , defined as follows:

$$f(x) = \mu \frac{x^n}{\nu^n + x^n}. \quad (16)$$

This function is a sigmoid, ranging in output value from zero to μ , attaining half its maximum value at $x = \nu$, and with the steepness of the sigmoid controlled by the exponent n . In the present simulations, the following parameter values were used: $\mu = 2$, $\nu = 1.1$, $n = 6$.

Thus, the equation for layer 4 spiny stellates is:

$$\frac{1}{\delta_C} \frac{d}{dt} y_{ijk} = -y_{ijk} + (1 - y_{ijk}) (C_{ijk} + \eta^+ x_{ijk}) - (y_{ijk} + 1) f \left(\sum_{pqr} W_{pqr}^+ m_{pqr} \right). \quad (17)$$

This was solved at equilibrium, giving:

$$y_{ijk} = \frac{C_{ijk} + \eta^+ x_{ijk} - f \left(\sum_{pqr} W_{pqr}^+ m_{pqr} \right)}{1 + C_{ijk} + \eta^+ x_{ijk} + f \left(\sum_{pqr} W_{pqr}^+ m_{pqr} \right)}. \quad (18)$$

Layer 4 inhibitory interneurons, m_{ijk} , also receive on-center off-surround input, the on-center again coming from layer 6 cells with the same position and orientation, x_{ijk} , and the off-surround inhibition coming via the spatial kernels, W^- , of the other inhibitory interneurons in layer 4 (Ahmed et al., 1997). These inhibitory-to-inhibitory synapses help to normalize the total amount of inhibition present at a given position in layer 4. Thus:

$$\frac{1}{\delta_m} \frac{d}{dt} m_{ijk} = -m_{ijk} + \eta^- x_{ijk} - m_{ijk} f \left(\sum_{pqr} W_{pqr}^- m_{pqr} \right). \quad (19)$$

As with the inhibitory-to-excitatory kernels, W^+ , the inhibitory-to-inhibitory kernels, W^- , are also linearly scaled versions of the kernels which were self-organized in the model of Grossberg and Williamson (2000). They have a very similar spatial structure to the W^+ kernels, but are a little stronger, as shown in Figure 7b. Parameters for layer 4 were: $\delta_m = 0.01875$, $\eta^+ = 2.1$, $\eta^- = 1.5$.

Layer 2/3

The pyramidal cells in layer 2/3, z_{ijk} , receive excitatory input from Layer 4 cells, y_{ijk} , at the same position and orientation (Callaway & Wiser, 1996), and also long-range bipole excitation from the thresholded outputs of other layer 2/3 pyramidals with collinear, coaxial receptive fields, $F(z_{ijk})$ (Bosking et al., 1997; Schmidt et al., 1997). Inhibitory interneurons in layer 2/3, s_{ijk} , also synapse onto these pyramidals, as shown in Figure 6c. As with the inhibitory kernels in layer 4, W^+ and W^- , the layer 2/3 cells synapse onto each other through linearly scaled versions of the self-organized kernels grown in the model of Grossberg and Williamson (2000). The excitatory-to-excitatory, long-range bipole kernels, H , are shown in Figure 8. As well the long-range excitation, layer 2/3 pyramidals also receive short-range inhibition from inhibitory interneurons at the same position and of the same orientation, s_{ijk} (McGuire et al., 1991). This inhibition operates through a self-organized short-range kernel, T^+ .

As remarked in Section 3 above, the present model extends that presented in Grossberg and Raizada (2000) by considering the possibility that attentional feedback might enter layer 2/3 directly, as well as via the indirect layer 6 \rightarrow 4 folded feedback path. In the direct path, feedback signals in layer 1 are collected by the apical dendrites of layer 2/3 pyramidals, and also by the dendrites of layer 2/3 inhibitory interneurons with dendrites in layer 1 (Lund & Wu, 1997). Thus, attention is carried directly into layer 2/3 by both excitatory and inhibitory neurons, creating a balance of excitation and inhibition which keeps the net effect of attention subthreshold, or modulatory. The coefficients which determine the relative inputs of attention into the layer 2/3 excitatory and inhibitory cells are denoted by a_{excit}^{23} and a_{inhib}^{23} , respectively.

Thus, the full equation for layer 2/3 pyramidals is as follows:

$$\frac{1}{\delta_z} \frac{d}{dt} z_{ijk} = -z_{ijk} + (1 - z_{ijk}) \left(\lambda [y_{ijk}]^+ + \sum_{pqr} H_{pqrijk} F(z_{pqr}, \Gamma) + a_{excit}^{23} att \right) - (z_{ijk} + \psi) \sum_r T_{rk}^+ s_{ijr}. \quad (20)$$

The layer 2/3 inhibitory interneurons, s_{ijk} receive excitation from layer 2/3 pyramidals, through the kernels H , and are inhibited by other layer 2/3 interneurons at the same position but of all orientations, via the self-organized short-range kernel, T^- (Tamas et al., 1998). Like the layer 2/3 pyramidals, they also receive direct attentional input, when attention is present:

$$\frac{1}{\delta_s} \frac{d}{dt} s_{ijk} = -s_{ijk} + \sum_{pqr} H_{pqrijk} F(z_{pqr}, \Gamma) + a_{inhib}^{23} att - s_{ijk} T_{rk}^- s_{ijr}. \quad (21)$$

Parameters for layer 2/3 were: $\delta_z = 0.0125$, $\delta_s = 2.5$, $\lambda = 1.5$, $\psi = 0.5$, $a_{excit}^{23} = 3$, $a_{inhib}^{23} = 0.5$.

Feedforward projections from V1 to V2

The thresholded output of V1 layer 2/3 projects forward to layers 6 and 4 of V2, x_{ijk}^{V2} and y_{ijk}^{V2} respectively, following the same pattern as the LGN forward projections to layers 6 and 4 of V1, as shown in Figure 6e. Hence:

$$\frac{1}{\delta_C} \frac{d}{dt} x_{ijk}^{V2} = -x_{ijk}^{V2} + (1 - x_{ijk}^{V2}) \left(V_{12}^6 F(z_{ijk}, \Gamma) + \phi F(z_{ijk}^{V2}, \Gamma) + att \right), \quad (22)$$

and

$$\frac{1}{\delta_C} \frac{d}{dt} y_{ijk}^{V2} = -y_{ijk}^{V2} + (1 - y_{ijk}^{V2}) \left(V_{12}^4 F(z_{ijk}, \Gamma) + \eta^+ x_{ijk}^{V2} \right) - (y_{ijk}^{V2} + 1) f \left(\sum_{pqr} W_{pqrijk}^+ m_{pqr}^{V2} \right). \quad (23)$$

All other equations and parameters for V2 are exactly the same as for the corresponding layers of V1, except that the length of the V2 bipole kernel, H^{V2} , is greater than that of V1, reflecting the fact that intrinsic horizontal connections have a longer range in V2 than in V1 (Amir et al., 1993), and also that illusory contours can form between more widely spaced inducers in V2 than in V1 (Sheth et al., 1996). The V2 bipole kernels are shown in Figure 8b. Parameters for the forward projection from V1 to V2 were: $V_{12}^6 = 1$, $V_{12}^4 = 5$.

Network inputs for the simulations

The simulations presented in this paper all used the same set of network parameters. The strengths of the raw inputs and, where applicable, the attentional Gaussians, were as follows: Crossover simulation (Figure 1): low contrast raw input strength, $I = 0.1$, high contrast raw input strength, $I = 0.6$. De Weerd et al. (1999) simulation (Figure 2): distractor contrast = 20%, peak value of attentional

Gaussian = 0.05. Knierim and Van Essen (1992) simulation (Figure 3): raw input strength, $I = 0.2$. Simulation of attention flow along a real contour (Figure 4): raw input strength, $I = 0.08$, peak value of attentional Gaussian = 0.02. Simulation of attention flow along an illusory contour (Figure 5): raw input strength, $I = 0.3$, peak value of attentional Gaussian = 0.02. All of the attentional simulations used an attentional Gaussian with a standard deviation of 1.5.

Self-organized kernels

The kernels, which were self-organized in the study by Grossberg and Williamson (2000), are represented here graphically (Figures 7 and 8), except for the single-pixel layer 2/3 inhibitory kernels, T^+ and T^- , which had the following self-organized equilibrium values. $T_{11}^+ = 0.9032$, $T_{21}^+ = 0.1384$, $T_{12}^+ = 0.1282$, $T_{22}^+ = 0.8443$. $T_{11}^- = 0.2719$, $T_{21}^- = 0.0428$, $T_{12}^- = 0.0388$, $T_{22}^- = 0.2506$. T^+ in V2 was 0.625 times the value of T^+ in V1.

a

Layer 4 inhibitory-to-excitatory kernel, W^+
from orientation $r = 1$ to orientation $k = 1$

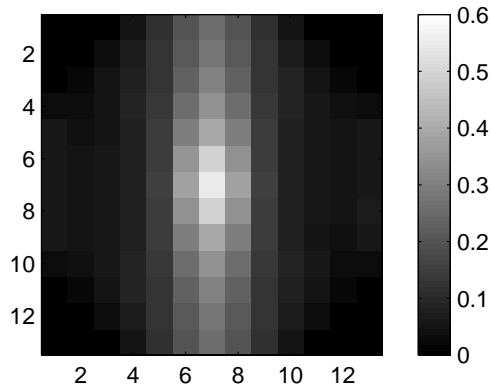

Layer 4 inhibitory-to-excitatory kernel, W^+
from orientation $r = 2$ to orientation $k = 1$

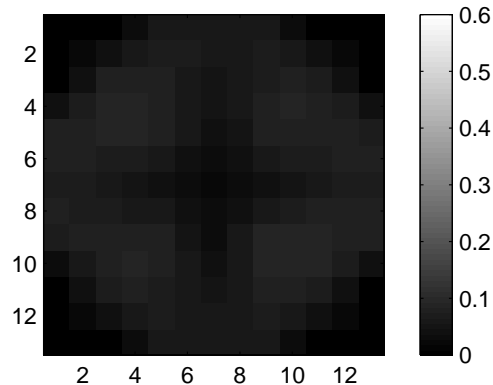

b

Layer 4 inhibitory-to-inhibitory kernel, W^-
from orientation $r = 1$ to orientation $k = 1$

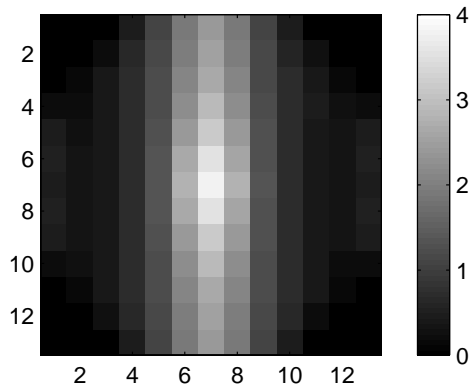

Layer 4 inhibitory-to-inhibitory kernel, W^-
from orientation $r = 2$ to orientation $k = 1$

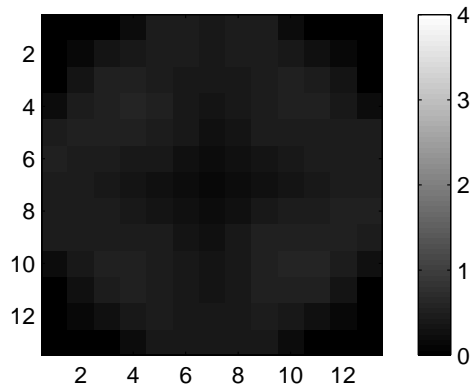

Figure 7: (a): The inhibitory-to-excitatory off-surround kernels in Layer 4, W^+ . Only the kernels operating on vertically oriented cells are shown, since those operating on horizontally oriented cells are the same, but rotated by ninety degrees. **(b):** The inhibitory-to-inhibitory off-surround kernels in Layer 4, W^- . Again, only the vertical kernels are shown.

aV1 layer 2/3 excitatory bipole kernel, H
from orientation $r = 1$ to orientation $k = 1$ V1 layer 2/3 excitatory bipole kernel, H
from orientation $r = 2$ to orientation $k = 2$ **b**V2 layer 2/3 excitatory bipole kernel, H
from orientation $r = 1$ to orientation $k = 1$ V2 layer 2/3 excitatory bipole kernel, H
from orientation $r = 2$ to orientation $k = 2$ 

Figure 8: (a): The bipole-grouping kernels in V1 layer 2/3, H . Since bipole facilitation is collinear, the cross-orientation bipole kernels have approximately zero strength. They are not shown. (b): The bipole-grouping kernels in V2 layer 2/3, H^{V2} . Note that they are longer-range than the corresponding V1 kernels.

References

- Ahmed, B., Anderson, J. C., Martin, K. A. C., & Nelson, J. C. (1997). Map of the synapses onto layer 4 basket cells of the primary visual cortex of the cat. *Journal of Comparative Neurology*, *380*, 230–242.
- Allman, J., Miezin, F., & McGuinness, E. (1985). Stimulus specific responses from beyond the classical receptive field: neurophysiological mechanisms for local-global comparisons in visual neurons. *Annual Review of Neuroscience*, *8*, 407–30.
- Alonso, J. M., & Martinez, L. M. (1998). Functional connectivity between simple cells and complex cells in cat striate cortex. *Nature Neuroscience*, *1*(5), 395–403.
- Amir, Y., Harel, M., & Malach, R. (1993). Cortical hierarchy reflected in the organization of intrinsic connections in macaque monkey visual cortex. *J. Comp. Neurol.*, *334*, 19–46.
- Baloch, A. A., Grossberg, S., Mingolla, E., & Nogueira, C. A. M. (1999). Neural model of first-order and second-order motion perception and magnocellular dynamics. *Journal of the Optical Society of America, A*, *16*, 953–978.
- Blakemore, C., & Tobin, E. A. (1972). Lateral inhibition between orientation detectors in the cat's visual cortex. *Experimental Brain Research*, *15*, 439–40.
- Blasdel, G. G., & Lund, J. S. (1983). Termination of afferent axons in macaque striate cortex. *Journal of Neuroscience*, *3*(7), 1389–1413.
- Blasdel, G. G., Lund, J. S., & Fitzpatrick, D. (1985). Intrinsic connections of macaque striate cortex: axonal projections of cells outside lamina 4C. *Journal of Neuroscience*, *5*(12), 3350–3369.
- Bosking, W., Zhang, Y., Schofield, B., & Fitzpatrick, D. (1997). Orientation selectivity and the arrangement of horizontal connections in tree shrew striate cortex. *Journal of Neuroscience*, *17*(6), 2112–2127.
- Brefczynski, J. A., & DeYoe, E. A. (1999). A physiological correlate of the 'spotlight' of visual attention. *Nature Neuroscience*, *2*, 370–4.
- Bullier, J., Hupé, J. M., James, A., & Girard, P. (1996). Functional interactions between areas V1 and V2 in the monkey. *Journal of Physiology (Paris)*, *90*(3-4), 217–20.
- Callaway, E. M. (1998). Local circuits in primary visual cortex of the macaque monkey. *Annual Review of Neuroscience*, *21*, 47–74.
- Callaway, E. M., & Wiser, A. K. (1996). Contributions of individual layer 2-5 spiny neurons to local circuits in macaque primary visual cortex. *Visual Neuroscience*, *13*, 907–922.
- Caputo, G., & Guerra, S. (1998). Attentional selection by distractor suppression. *Vision Research*, *38*(5), 669–689.
- Cauler, L. J., & Connors, B. W. (1994). Synaptic physiology of horizontal afferents to layer I in slices of rat SI neocortex. *Journal of Neuroscience*, *14*(2), 751–762.
- Chey, J., Grossberg, S., & Mingolla, E. (1997). Neural dynamics of motion grouping: from aperture ambiguity to object speed and direction. *Journal of the Optical Society of America, A*, *14*, 2570–2594.

- Chey, J., Grossberg, S., & Mingolla, E. (1998). Neural dynamics of motion processing and speed discrimination. *Vision Research*, *38*, 2769–2786.
- Davis, G., & Driver, J. (1997). Spreading of visual attention to modally versus amodally completed regions. *Psychological Science*, *8*, 275–81.
- De Weerd, P., Peralta, M. R., Desimone, R., & Ungerleider, L. G. (1999). Loss of attentional stimulus selection after extrastriate cortical lesions in macaques. *Nature Neuroscience*, *2*, 753–8.
- Downing, C. J. (1988). Expectancy and visual-spatial attention: effects on perceptual quality. *Journal of Experimental Psychology: Human Perception and Performance*, *14*(2), 188–202.
- Ferster, D., Chung, S., & Wheat, H. (1996). Orientation selectivity of thalamic input to simple cells of cat visual cortex. *Nature*, *380*, 249–252.
- Field, D. J., Hayes, A., & Hess, R. F. (1993). Contour integration by the human visual system: evidence for a local "association field". *Vision Research*, *33*, 173–93.
- Finkel, L. H., & Edelman, G. M. (1989). Integration of distributed cortical systems by reentry: a computer simulation of interactive functionally segregated visual areas. *Journal of Neuroscience*, *9*, 3188–208.
- Fitzpatrick, D., Lund, J. S., & Blasdel, G. G. (1985). Intrinsic connections of macaque striate cortex: afferent and efferent connections of lamina 4C. *Journal of Neuroscience*, *5*(12), 3329–3349.
- Francis, G., Grossberg, S., & Mingolla, E. (1994). Cortical dynamics of feature binding and reset: control of visual persistence. *Vision Research*, *34*, 1089–104.
- Gattass, R., Sousa, A., Mishkin, M., & Ungerleider, L. (1997). Cortical projections of area V2 in the macaque. *Cerebral Cortex*, *7*(2), 110–29.
- Gilbert, C. D., & Wiesel, T. N. (1979). Morphology and intracortical projections of functionally characterised neurones in the cat visual cortex. *Nature*, *280*, 120–125.
- Gilbert, C. D., & Wiesel, T. N. (1990). The influence of contextual stimuli on the orientation selectivity of cells in primary visual cortex of the cat. *Vision Research*, *30*, 1689–701.
- Glass, L. (1969). Moire effect from random dots. *Nature*, *223*, 578–80.
- Gove, A., Grossberg, S., & Mingolla, E. (1995). Brightness perception, illusory contours, and corticogeniculate feedback. *Visual Neuroscience*, *12*(6), 1027–52.
- Gray, C. M. (1999). The temporal correlation hypothesis of visual feature integration: still alive and well. *Neuron*, *24*, 31–47.
- Grosovsky, D. H., Shapley, R. M., & Hawken, M. J. (1993). Macaque V1 neurons can signal 'illusory' contours. *Nature*, *365*, 550–552.
- Grossberg, S. (1970). Neural pattern discrimination. *Journal of Theoretical Biology*, *27*(2), 291–337.
- Grossberg, S. (1973). Contour enhancement, short term memory, and constancies in reverberating neural networks. *Studies in Applied Mathematics*, *52*, 217–257. Reprinted in *Studies of Mind and Brain*, S. Grossberg (1982). D. Reidel Publishing Company: Dordrecht, Holland.
- Grossberg, S. (1980). How does a brain build a cognitive code?. *Psychological Review*, *87*, 1–51.

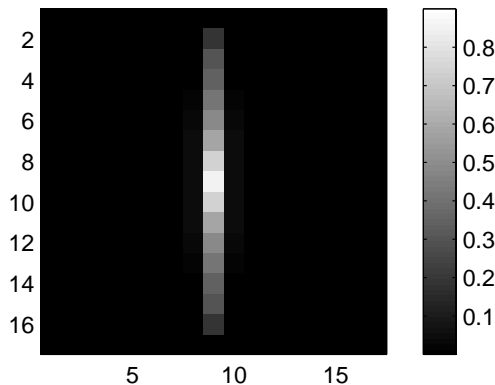
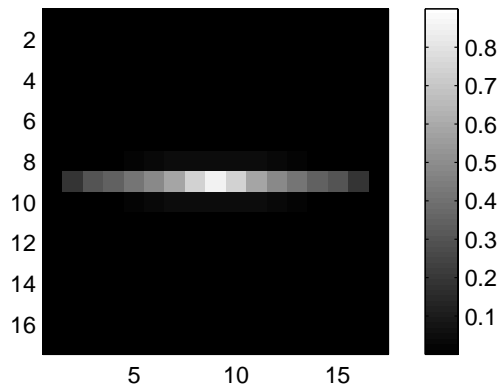
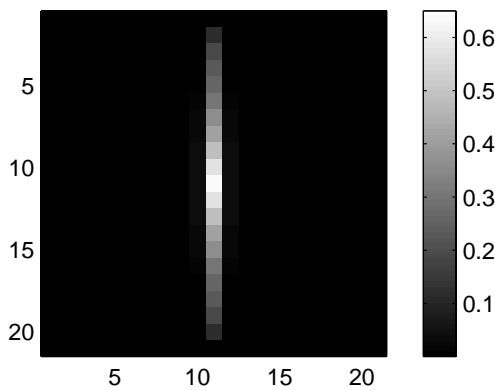
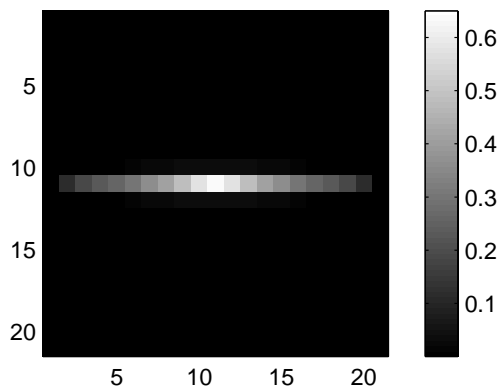
- Grossberg, S. (1994). 3-D vision and figure-ground separation by visual cortex. *Perception and Psychophysics*, *55*(1), 48–120.
- Grossberg, S. (1998). How is a moving target continuously tracked behind occluding cover?. In Watanabe, T. (Ed.), *High-Level Motion Processing: Computational, Neurobiological, and Psychophysical Perspectives*, pp. 1–30. MIT Press, Cambridge, MA.
- Grossberg, S. (1999a). How does the cerebral cortex work? Learning, attention, and grouping by the laminar circuits of visual cortex. *Spatial Vision*, *12*, 163–187.
- Grossberg, S. (1999b). The link between brain learning, attention, and consciousness. *Consciousness and Cognition*, *8*, 1–44.
- Grossberg, S. (2000). The imbalanced brain: from normal behavior to schizophrenia. *Biological Psychiatry*, in press.
- Grossberg, S., & Grunewald, A. (1997). Cortical synchronization and perceptual framing. *Journal of Cognitive Neuroscience*, *9*(1), 117–132.
- Grossberg, S., & Kelly, F. (1999). Neural dynamics of binocular brightness perception. *Vision Research*, *39*, 3796–3816.
- Grossberg, S., & Mingolla, E. (1985). Neural dynamics of form perception: boundary completion, illusory figures, and neon color spreading. *Psychological Review*, *92*(2), 173–211.
- Grossberg, S., Mingolla, E., & Ross, W. D. (1997). Visual brain and visual perception: how does the cortex do perceptual grouping?. *Trends in Neurosciences*, *20*(3), 106–111.
- Grossberg, S., & Raizada, R. D. S. (2000). Contrast-sensitive perceptual grouping and object-based attention in the laminar circuits of primary visual cortex. *Vision Research*, *40*, 1413–1432.
- Grossberg, S., & Somers, D. (1991). Synchronized oscillations during cooperative feature linking in a cortical model of visual perception. *Neural Networks*, *4*(4), 453–466.
- Grossberg, S., & Williamson, J. R. (2000). A neural model of how visual cortex develops a laminar architecture capable of adult perceptual grouping. Boston University Technical Report CAS/CNS-98-022. Forthcoming in *Cerebral Cortex*.
- Harth, E., Unnikrishnan, K. P., & Pandya, A. S. (1987). The inversion of sensory processing by feedback pathways: a model of visual cognitive functions. *Science*, *237*, 184–7.
- He, Z. J., & Nakayama, K. (1995). Visual attention to surfaces in three-dimensional space. *Proceedings of the National Academy of Sciences, USA*, *21*, 11155–9.
- Heeger, D. J. (1992). Normalization of cell responses in cat striate cortex. *Visual Neuroscience*, *9*(2), 181–97.
- Heitger, F., von der Heydt, R., Peterhans, E., Rosenthaler, L., & Kubler, O. (1998). Simulation of neural contour mechanisms: representing anomalous contours. *Image and Vision Computing*, *16*, 407–421.
- Hirsch, J. A., Alonso, J. M., & Reid, R. C. Martinez, L. M. (1998). Synaptic integration in striate cortical simple cells. *Journal of Neuroscience*, *18*(22), 9517–28.

- Hirsch, J. A., & Gilbert, C. D. (1991). Synaptic physiology of horizontal connections in the cat's visual cortex. *Journal of Neuroscience*, *11*(6), 1800–1809.
- Ito, M., & Gilbert, C. D. (1999). Attention modulates contextual influences in the primary visual cortex of alert monkeys. *Neuron*, *22*, 593–604.
- Kanizsa, G. (1979). *Organization in vision : essays on Gestalt perception*. Praeger, New York.
- Kapadia, M. K., Ito, M., Gilbert, C. D., & Westheimer, G. (1995). Improvement in visual sensitivity by changes in local context: parallel studies in human observers and in V1 of alert monkeys. *Neuron*, *15*, 843–856.
- Kapadia, M. K., Westheimer, G., & Gilbert, C. D. (1998). Spatial distribution and dynamics of contextual interactions in cortical area V1. *Society for Neuroscience Abstracts*, *789.6*.
- Kisvarday, Z. F., Cowey, A., Smith, A. D., & Somogyi, P. (1989). Interlaminar and lateral excitatory amino acid connections in the striate cortex of monkey. *Journal of Neuroscience*, *9*(2), 667–682.
- Knierim, J. J., & Van Essen, D. C. (1992). Neuronal responses to static texture patterns in area V1 of the alert macaque monkey. *Journal of Neurophysiology*, *67*, 961–80.
- Kovacs, I., & Julesz, B. (1993). A closed curve is much more than an incomplete one: effect of closure in figure-ground segmentation. *Proceedings of the National Academy of Sciences, USA*, *90*(16), 7495–7.
- Lamme, V. A. F. (1998). The neurophysiology of figure-ground segregation in primary visual cortex. *Journal of Neuroscience*, *15*, 1605–15.
- Li, Z. (1998). A neural model of contour integration in the primary visual cortex. *Neural Computation*, *10*, 903–940.
- Luck, S. J., Chelazzi, L., Hillyard, S. A., & Desimone, R. (1997). Neural mechanisms of spatial selective attention in areas V1, V2, and V4 of macaque visual cortex. *Journal of Neurophysiology*, *77*, 24–42.
- Lumer, E. D., Edelman, G. M., & Tononi, G. (1997). Neural dynamics in a model of the thalamocortical system. I. Layers, loops and the emergence of fast synchronous rhythms. *Cerebral Cortex*, *7*, 207–27.
- Lund, J. S., & Boothe, R. G. (1975). Interlaminar connections and pyramidal neuron organisation in the visual cortex, area 17, of the macaque monkey. *Journal of Comparative Neurology*, *159*, 305–334.
- Lund, J. S., & Wu, C. Q. (1997). Local circuit neurons of macaque monkey striate cortex: IV. Neurons of laminae 1-3A. *Journal of Comparative Neurology*, *384*, 109–126.
- Maffei, L., & Fiorentini, A. (1976). The unresponsive regions of visual cortical receptive fields. *Vision Research*, *16*, 1131–9.
- Markram, H., Wang, Y., & Tsodyks, M. (1998). Differential signaling via the same axon of neocortical pyramidal neurons. *Proceedings of the National Academy of Sciences, USA*, *95*, 5323–8.
- McCormick, D. A., Connors, B. W., Lighthall, J. W., & Prince, D. A. (1985). Comparative electrophysiology of pyramidal and sparsely spiny stellate neurons of the neocortex. *Journal of Neurophysiology*, *54*, 782–806.

- McGuire, B. A., Gilbert, C. D., Rivlin, P. K., & Wiesel, T. N. (1991). Targets of horizontal connections in macaque primary visual cortex. *Journal of Comparative Neurology*, 305(3), 370–392.
- McGuire, B. A., Hornung, J. P., Gilbert, C. D., & Wiesel, T. N. (1984). Patterns of synaptic input to layer 4 of cat striate cortex. *Journal of Neuroscience*, 4(12), 3021–3033.
- Montero, V. M. (1991). A quantitative study of synaptic contacts on interneurons and relay cells of the cat lateral geniculate nucleus. *Experimental Brain Research*, 86, 257–70.
- Moore, C. M., & Egeth, H. (1997). Perception without attention: evidence of grouping under conditions of inattention. *Journal of Experimental Psychology: Human Perception and Performance*, 23(2), 339–352.
- Moore, C. M., Yantis, S., & Vaughan, B. (1998). Object-based visual selection: Evidence from perceptual completion. *Psychological Science*, 9, 104–110.
- Motter, B. C. (1993). Focal attention produces spatially selective processing in visual cortical areas V1, V2 and V4 in the presence of competing stimuli. *Journal of Neurophysiology*, 70, 909–919.
- Mounts, J. R. W. (2000). Evidence for suppressive mechanisms in attentional selection: Feature singletons produce inhibitory surrounds. *Perception and Psychophysics*, in press.
- Mumford, D. (1992). On the computational architecture of the neocortex. II. The role of cortico-cortical loops. *Biological Cybernetics*, 1992, 241–51.
- Nelson, J. I., & Frost, B. J. (1978). Orientation-selective inhibition from beyond the classic visual receptive field. *Brain Research*, 139, 359–65.
- Neumann, H., & Sepp, W. (1999). Recurrent V1-V2 interaction in early visual boundary processing. *Biological Cybernetics*, 81, 425–44.
- Nguyen, M., & Lee, T. S. (1999). Spatiotemporal dynamics of subjective contour formation in primate V1 and V2. *Society for Neuroscience Abstracts*, 7.3.
- Nothdurft, H. C. (1991). Texture segmentation and pop-out from orientation contrast. *Vision Research*, 31, 1073–8.
- Nothdurft, H. C., Gallant, J. L., & Van Essen, D. C. (1999). Response modulation by texture surround in primate area V1: correlates of "popout" under anesthesia. *Vision Neuroscience*, 16, 15–34.
- Olshausen, B. A., Anderson, C. H., & Van Essen, D. C. (1993). A neurobiological model of visual attention and invariant pattern recognition based on dynamic routing of information. *Journal of Neuroscience*, 13, 4700–19.
- Peterhans, E., & von der Heydt, R. (1989). Mechanisms of contour perception in monkey visual cortex. II. Contours bridging gaps. *Journal of Neuroscience*, 9, 1749–63.
- Peters, A. G., & Sethares, C. (1991). Organization of pyramidal neurons in area 17 of monkey visual cortex. *Journal of Comparative Neurology*, 306, 1–23.
- Polat, U., Mizobe, K., Pettet, M. W., Kasamatsu, T., & Norcia, A. M. (1998). Collinear stimuli regulate visual responses depending on cell's contrast threshold. *Nature*, 391, 580–584.
- Polat, U., & Sagi, D. (1993). Lateral interactions between spatial channels: suppression and facilitation revealed by lateral masking experiments. *Vision Research*, 33, 993–9.

- Przybylski, A. W., Foote, W., & Pollen, D. A. (1998). Contrast gain control of the LGN neurons by V1. *Investigative Ophthalmology and Visual Science (Suppl.)*, *38*, S238. (Abstract).
- Rao, R. P. N., & Ballard, D. H. (1999). Predictive coding in the visual cortex: a functional interpretation of some extra-classical receptive field effects. *Nature Neuroscience*, *2*, 79–87.
- Redies, C., Crook, J. M., & Creutzfeldt, O. D. (1986). Neuronal responses to borders with and without luminance gradients in cat visual cortex and dorsal lateral geniculate nucleus. *Experimental Brain Research*, *61*, 469–481.
- Reid, R. C., & Alonso, J. M. (1995). Specificity of monosynaptic connections from thalamus to visual cortex. *Nature*, *378*, 281–4.
- Reyes, A., Lujan, R., Rozov, A., Burnashev, N., Somogyi, P., & Sakmann, B. (1998). Target-cell-specific facilitation and depression in neocortical circuits. *Nature Neuroscience*, *1*, 279–85.
- Reynolds, J., Chelazzi, L., & Desimone, R. (1999). Competitive mechanisms subserve attention in macaque areas V2 and V4. *Journal of Neuroscience*, *19*, 1736–53.
- Reynolds, J. H., & Desimone, R. (1999). The role of neural mechanisms of attention in solving the binding problem. *Neuron*, *24*, 19–29.
- Rockland, K. S. (1994). The organization of feedback connections from area V2 (18) to V1 (17). In Peters, A., & Rockland, K. S. (Eds.), *Cerebral Cortex*, Vol. 10, pp. 261–299. Plenum Press, New York.
- Rockland, K. S., & Virga, A. (1989). Terminal arbors of individual "feedback" axons projecting from area V2 to V1 in the macaque monkey: a study using immunohistochemistry of anterogradely transported phaseolus vulgaris-leucoagglutinin. *Journal of Comparative Neurology*, *285*(1), 54–72.
- Rockland, K. S., & Virga, A. (1990). Organization of individual cortical axons projecting from area V1 (area 17) to V2 (area 18) in the macaque monkey. *Visual Neuroscience*, *4*(1), 11–28.
- Roelfsema, P. R., Lamme, V. A. F., & Spekreijse, H. (1998). Object-based attention in the primary visual cortex of the macaque monkey. *Nature*, *395*, 376–381.
- Roelfsema, P. R., & Spekreijse, H. (1999). Correlates of a gradual spread of attention over a traced curve in macaque area V1. *Society for Neuroscience Abstracts*, *7.2*.
- Ross, W. D., Mingolla, E., & Grossberg, S. (2000). Visual cortical mechanisms of perceptual grouping: Interacting layers, networks, columns, and maps. Boston University Technical Report CAS/CNS-98-023. Forthcoming in *Neural Networks*.
- Salin, P., & Bullier, J. (1995). Corticocortical connections in the visual system: structure and function. *Physiological Reviews*, *75*(1), 107–154.
- Sandell, J. H., & Schiller, P. H. (1982). Effect of cooling area 18 on striate cortex cells in the squirrel monkey. *Journal of Neurophysiology*, *48*(1), 38–48.
- Schiller, P. H. (1992). The ON and OFF channels of the visual system. *Trends in Neurosciences*, *15*(3), 86–92.

- Schmidt, K. E., Goebel, R., Löwel, S., & Singer, W. (1997). The perceptual grouping criterion of colinearity is reflected by anisotropies of connections in the primary visual cortex. *European Journal of Neuroscience*, *9*, 1083–1089.
- Sheth, B. R., Sharma, J., Rao, S. C., & Sur, M. (1996). Orientation maps of subjective contours in visual cortex. *Science*, *274*, 2110–2115.
- Sillito, A. M., Grieve, K. L., Jones, H. E., Cudeiro, J., & Davis, J. (1995). Visual cortical mechanisms detecting focal orientation discontinuities. *Nature*, *378*, 492–496.
- Sillito, A. M., Jones, H. E., Gerstein, G. L., & West, D. C. (1994). Feature-linked synchronization of thalamic relay cell firing induced by feedback from the visual cortex. *Nature*, *369*, 479–482.
- Smith, A. T., Singh, K. D., & Greenlee, M. W. (2000). Attentional suppression of activity in the human visual cortex. *Neuroreport*, *11*, 271–7.
- Somers, D. C., Dale, A. M., Seiffert, A. E., & Tootell, R. B. (1999). Functional MRI reveals spatially specific attentional modulation in human primary visual cortex. *Proceedings of the National Academy of Sciences, USA*, *96*, 1663–8.
- Somers, D. C., Todorov, E. V., Siapas, A. G., Toth, L. J., Kim, D., & Sur, M. (1998). A local circuit approach to understanding integration of long-range inputs in primary visual cortex. *Cerebral Cortex*, *8*, 204–217.
- Stemmler, M., Usher, M., & Niebur, E. (1995). Lateral interactions in primary visual cortex: A model bridging physiology and psychophysics. *Science*, *269*, 1877–1880.
- Stratford, K. J., Tarczy-Hornoch, K., Martin, K. A. C., Bannister, N. J., & Jack, J. J. B. (1996). Excitatory synaptic inputs to spiny stellate cells in cat visual cortex. *Nature*, *382*, 258–261.
- Sugita, Y. (1999). Grouping of image fragments in primary visual cortex. *Nature*, *401*, 269–72.
- Tamas, G., Somogyi, P., & Buhl, E. H. (1998). Differentially interconnected networks of GABAergic interneurons in the visual cortex of the cat. *Journal of Neuroscience*, *18*(11), 4255–4270.
- Thomson, A. M. (1997). Activity-dependent properties of synaptic transmission at two classes of connections made by rat neocortical pyramidal axons in vitro. *Journal of Physiology*, *502*, 131–47.
- Thorpe, S., Fize, D., & Marlot, C. (1996). Speed of processing in the human visual system. *Nature*, *381*, 520–522.
- Treisman, A. (1999). Solutions to the binding problem: Progress through controversy and convergence. *Neuron*, *24*, 105–110.
- Treue, S., & Maunsell, J. H. R. (1996). Attentional modulation of visual motion processing in cortical areas mt and mst. *Nature*, *382*, 539–541.
- Tsotsos, J., Culhane, S., Wai, W., Lai, Y., Davis, N., & Nuflo, F. (1995). Modeling visual attention via selective tuning. *Artificial Intelligence*, *78*, 507–547.
- Ullman, S. (1995). Sequence seeking and counter streams: a computational model for bidirectional information flow in the visual cortex. *Cerebral Cortex*, *5*, 1–11.

- Usher, M., & Niebur, E. (1996). Modeling the temporal dynamics of it neurons in visual search: A mechanism for top-down selective attention. *Journal of Cognitive Neuroscience*, 8, 311–327.
- Valverde, F. (1985). The organizing principles of the primary visual cortex in the monkey. In Peters, A., & Jones, E. G. (Eds.), *Cerebral Cortex*, Vol. 3, pp. 207–257. Plenum, New York.
- Van Essen, D. C., Newsome, W. T., Maunsell, J. H., & Bixby, J. L. (1986). The projections from striate cortex (V1) to areas V2 and V3 in the macaque monkey: asymmetries, areal boundaries, and patchy connections. *Journal of Comparative Neurology*, 244(4), 451–480.
- Vanduffel, W., Tootell, R. B., & Orban, G. A. (2000). Attention-dependent suppression of metabolic activity in the early stages of the macaque visual system. *Cerebral Cortex*, 2000, 109–26.
- Varela, J. A., Song, S., Turrigiano, G. G., & Nelson, S. B. (1999). Differential depression at excitatory and inhibitory synapses in visual cortex. *Journal of Neuroscience*, 19, 4293–304.
- von der Heydt, R., Peterhans, E., & Baumgartner, G. (1984). Illusory contours and cortical neuron responses. *Science*, 224, 1260–2.
- Watanabe, T., Sasaki, Y., Nielsen, M., Takino, R., & Miyakawa, S. (1998). Attention-regulated activity in human primary visual cortex. *Journal of Neurophysiology*, 79, 2218–2221.
- Williams, L. R., & Jacobs, D. W. (1997). Stochastic completion fields: A neural model of illusory contour shape and salience. *Neural Computation*, 9, 837–858.
- Wiser, A. K., & Callaway, E. M. (1997). Ocular dominance columns and local projections of layer 6 pyramidal neurons in macaque primary visual cortex. *Visual Neuroscience*, 14, 241–251.
- Yen, S. C., & Finkel, L. H. (1998). Extraction of perceptually salient contours by striate cortical networks. *Vision Research*, 38(5), 719–741.