

A real time fault analysis tool for monitoring operation of transmission line protective relay

Nan Zhang, Mladen Kezunovic*

*Department of Electrical and Computer Engineering, Texas A&M University,
College Station, TX 77843-3128, USA*

Received 14 December 2005; received in revised form 13 March 2006; accepted 23 March 2006
Available online 27 April 2006

Abstract

This paper proposes an integrated real time fault analysis tool for transmission line. The two primary techniques used in the fault analysis tool, fuzzy adaptive resonance theory (ART) neural network and synchronized sampling, can offer accurate fault detection, classification, internal/external fault differentiation, and fault location. The paper makes several extensions of the two techniques so that they can fit well in the realistic situations. The hardware configuration and software implementation are proposed in the paper. A comprehensive evaluation study is implemented to compare the proposed fault analysis tool with the traditional distance relay. Simulation results indicate that the integration exemplifies the advantages of both techniques and that the integrated solution has much better performance in different system conditions compared to distance relay. Both dependability and security of transmission line protection system are improved by using the proposed tool.

© 2006 Elsevier B.V. All rights reserved.

Keywords: Fault analysis; Fault location; Neural networks; Power system protection; Synchronized sampling

1. Introduction

Traditional transmission line protective relaying principles rely on phasor calculation as well as phasor comparison against the predetermined settings. The accuracy of such methods will be degraded when the fault condition and system operating condition are quite different from the expected ones. The relay system failures contribute to 70% of large area disturbances and cascading blackouts [1]. The vulnerable relays in the system need to be closely monitored to prevent the relay misoperations and reduce the risk of a large-scale blackout [2].

A complete fault analysis tool should provide accurate and detailed fault information such as fault detection, fault type classification, internal/external fault differentiation, fault location, etc. If such fault analysis tools have much better performance than traditional relays, it can be used on-line to confirm the impact of disturbances and monitor the relay operations so that the system operator can obtain the detailed information about the relay operation outcomes before he/she issues corrective con-

trols. It can also be used off-line for trouble-shooting after the disturbances.

Different new techniques have been used in the fault analysis tools. An expert system based approach is described in [3] and a phasor measurement unit (PMU) based approach is described in [4]. Those approaches still depend on the phasor calculation. A neural network based fault analysis tool is developed in [5], but it is hard to obtain a precise fault location since neural network is not good at precisely classifying the continuous variables. A synchronized sampling based fault analysis is introduced in [6], but the application is limited to short lines. Methods based on traveling waves and recently based on fault-generated high-frequency transients have been used extensively in protection schemes [7–12]. Most of those techniques require very high sampling rate, which is still not widely used in existing devices.

This paper proposes a new integrated fault analysis tool for transmission lines using two major techniques, neural network and synchronized sampling. Previous theoretical studies demonstrate the advantages when using neural networks in fault classification [13] and synchronized sampling in fault location [14]. Both of the techniques use time-domain signals directly and are derived using the principles that are quite different from

* Corresponding author. Tel.: +1 979 845 7509; fax: +1 979 845 9887.
E-mail address: kezunov@ece.tamu.edu (M. Kezunovic).

the traditional transmission line relays. Since the two techniques can share the same hardware, using them in the integrated fault analysis tool is promising. Apart from the previous efforts in the algorithm tune-up of each individual prototype technique [13,14], this paper puts an emphasis on the integrated solution for the complete fault analysis tool. The remaining application issues for both techniques to be able to take into account the realistic situations are described and solved. The extensive and optimized uses of the prototype approaches are demonstrated. The feasible hardware configuration and software implementation schemes are proposed. A comprehensive evaluation study is implemented to compare the proposed fault analysis tool with the traditional distance relay.

2. Background

2.1. Neural network algorithm

Neural network based fault analysis algorithms differ from the traditional distance relay algorithms in: (a) using the time-domain voltage and current signals directly as patterns instead of calculating phasors and (b) comparing the input voltage and current signals with well-trained prototypes instead of predetermined settings. Hence, the major problems in traditional relay principles, phasor extraction and setting coordination, are not an issue in neural network based algorithms.

The existing neural network based approaches dominantly use multi-layer perceptron (MLP) in handling the large input data set. With the unique advantage to deal with the convergence issue in training, a self-organized, adaptive resonance theory (ART) based neural network algorithm is used in [13] for transmission line fault classification.

The structure of this Fuzzy ART neural network algorithm is demonstrated using Fig. 1. The prototypes of the two key components of the algorithm, ART neural network and Fuzzy K-nearest neighbor (K-NN), can be found in [15,16]. Thousands of patterns obtained from power system simulation or substation database of field recordings are used to train the neural network

off-line through a combined supervised and unsupervised learning process to obtain the prototype of each group of similar scenarios (clusters). Fuzzy K-NN is then used on-line for classifying the unknown pattern to identify whether it corresponds to a fault and what type of fault it is.

2.2. Synchronized sampling algorithm

Fault location techniques can be classified into two categories: (a) using data from one transmission line end and (b) using data from two ends. When using data from one end the algorithm usually needs to have assumptions about fault resistance and current ratios and will suffer from the errors in unexpected system conditions. When using data from two ends the algorithms are more accurate and become more feasible since the new techniques such as global positioning system (GPS) of satellites, phasor measurement unit (PMU), fiber optics and high-speed Ethernet are further developed and applied in power system [17].

The prototype of fault location algorithm based on synchronized sampling was developed in [14]. The inputs of the algorithm are raw samples of voltage and current synchronously taken from two ends of the transmission line.

The basic principle is that on a faulted line, the voltage and current at the faulted point can be represented by both sending data and receiving data using certain linear relationship. Different algorithms use different techniques to find that point.

For short transmission line model that can be represented using lumped parameters, the fault location can be calculated directly by solving the differential equations. The explicit form of fault location can be represented using least square estimate method [14].

For long line model, an indirect method is used with the help of Bergeron's equation [18]. The calculation steps are shown in Fig. 2.

Compared to the fault location algorithms using one end data, this method makes no assumptions about fault parameters and system operating condition. Therefore it is less affected by those factors.

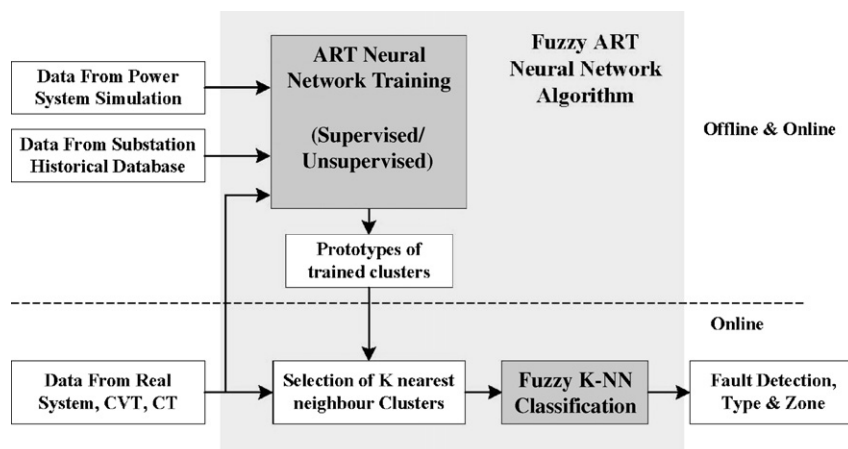

Fig. 1. Application of Fuzzy ART neural network for fault detection and classification.

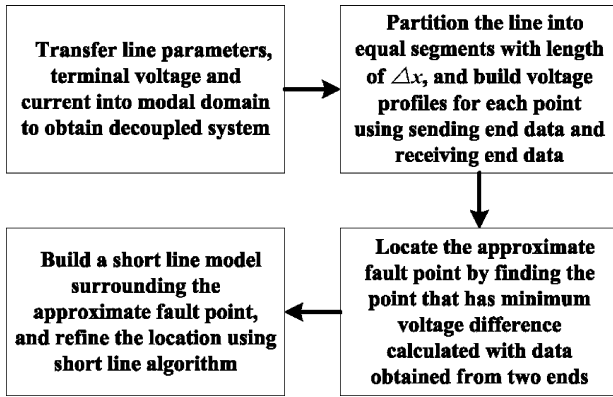

Fig. 2. Steps for long line fault location algorithm.

3. Design of the integrated fault analysis tool

3.1. Overall consideration

The objective of the automated fault analysis tool proposed in this paper is to work in parallel with traditional relay and to be a relay monitoring tool using more accurate fault detection, fault type classification and fault location. The new fault analysis tool should have the capability to confirm if the relay operation is correct. Such a fault analysis tool can be used as one of the following three schemes:

3.1.1. Localized scheme

By this scheme, the fault analysis tool is installed in the substation and used as real time relay monitoring tool. If authorized, it can correct the relay operations when it confirms that the relay has made a wrong decision and misoperated. Only the fault analysis result is sent to the control center.

3.1.2. Centralized scheme

By this scheme, the fault analysis tool is installed in the control center and performs the analysis for all suspect areas. The tool will not correct the relay operations directly but will serve as a reference for the system operator. The system operator will coordinate the system and control means to make a better decision to mitigate the disturbance.

3.1.3. Hybrid scheme

By this scheme, part of the fault analysis tool such as fault detection and classification can be installed in local substation to monitor the traditional relays. If different results are obtained between fault analysis tool and traditional relay, an alarm signal is sent to the control center. Then another part of the tool such as fault location confirms the outcome and the system operator will take the corrective controls.

This paper will focus on the fault analysis tool design aimed at a localized scheme. The design can also be used in the other two schemes with minor changes in hardware and software. By using the combined techniques of neural network and synchronized sampling in a fault analysis tool, we can expect several benefits: (a) eliminate the phasor and setting concepts used in the traditional relay to avoid their related problems, (b) inherit

the advantages over the traditional relay principle from both techniques, (c) exemplify their strengths in fault classification and fault location respectively, and (d) confirm the decisions made by each individual technique to get a more convincing result.

Before designing the integrated fault analysis tool, several application issues for neural network based algorithm and synchronized sampling based algorithm need to be discussed. The design of the integrated tool will take into account those issues and provide the solutions. An efficient use of the hardware and coordination of the software is the key issue in the design of the new fault analysis tool.

3.2. Application issues

3.2.1. Issues in using neural network

The transmission line fault has great randomness because the fault can occur anywhere in the system with different combination of fault parameters and system operating conditions. The argument that neural network based algorithm has better performance than conventional relay is based on an assumption that the neural network has broader view of system contingencies after a comprehensive learning and training process. The neural network based algorithms thus face the issue of dealing with a large set of training data. How to train the network efficiently when taking into account the large number of system-wide scenarios is very important.

Most of the neural network based algorithms implement the training using fixed post-fault data window. An assumption is made that one can identify the exact fault inception point, otherwise the real pattern is quite different from those learned and the performance of neural network will be degraded. In realistic situation, the inception point needs to be well identified to ensure the performance of the neural network based algorithm.

The neural network based algorithm should also take into account the impact from non-fault situations such as overload and power swing. If the input pattern uses raw voltage and current samples, the waveforms during the overload and power swing may appear as low voltage or high current, which may be confused with the waveforms during the fault.

The above issues were not considered in the previous implementation of the Fuzzy ART neural network algorithms. This paper will provide new schemes when applying neural network in the integrated tool to take into account those issues.

3.2.2. Issues in using synchronized sampling

Fault location is usually used for maintenance purpose for quickly finding the fault and repairing the line. If the fault can be located accurately in a very short time, one can confirm the fault occurrence and identify the faulted line section. The unnecessary removal of healthy lines can be blocked or corrected. That is very important in preventing the unfolding cascades leading to blackouts.

The prototype of synchronized sampling based fault location algorithm, especially for the long line model, requires transmission of large data-set and a very complex calculation procedure. Those issues make it too slow for on-line application. Since syn-

chronized data from two ends are used, it is possible to separate the algorithm into two stages: (a) confirm whether the fault is internal or external using limited data and simplified calculation and (b) locate the accurate fault place using more data and longer time.

This paper will derive a new differential scheme for the first stage of the algorithm and then propose an approach to optimize the second stage of the algorithm when other fault information from the fault analysis tool is available.

3.3. Components of the fault analysis tool

3.3.1. Pick-up unit (PU)

The pick-up unit is used to locate the exact inception time of fault or other disturbances, which is very important for both neural network based algorithm and synchronized sampling based algorithm since they both assume the post-fault values are used. The criterion of pick-up unit is defined as:

$$\left| i(k) + 2i \left(k - \frac{N}{2} \right) + i(k - N) \right| \geq T_1 \quad (1)$$

where i is the current signal in any of the three phases, k the present sampling point, and N is the number of sampling points in a cycle.

In the ideal situation, the left side of Eq. (1) equals to zero during the steady state and to a big value during the disturbances. Eq. (1) has taken into account the impact from the frequency variation during the steady state. In reality, a threshold T_1 must be set to take into account the model and measurement imperfection. If Eq. (1) is satisfied in any of the three phases for a consecutive cycle, the first sample point is considered as the inception time to trigger the successive fault analysis.

3.3.2. Neural network based fault detection and classification (NNFDC)

Neural network uses one end data to perform fault detection, classification of fault type and fault zone. It has the same functions as distance relay. The training and on-line testing of the NNFDC take the process as shown in Fig. 1, while the input, output and the use of original algorithm are tuned.

To deal with the system-wide disturbances effectively, the task of fault detection and classification is assigned by training two neural networks. The scheme is demonstrated using a system with specific configuration shown in Fig. 3.

To protect the line of interest in Fig. 3, the first neural network (NN1) makes a crude differentiation of the disturbances occurring within and around the line of interest (the highlighted area) from those occurring outside that area. The training of NN1 will take into account, as many as possible, fault events throughout

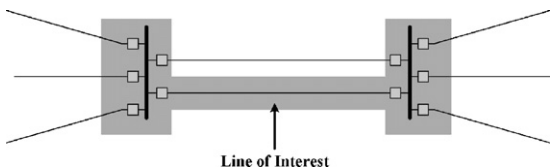

Fig. 3. A specific system configuration.

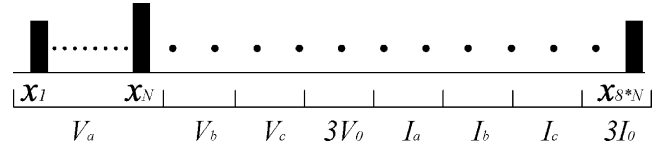

Fig. 4. Input pattern arrangement for neural networks.

the entire system that may affect the desired fault detection and classification. The training process is not significantly involved since there are only two outputs, “fault” and “no fault”. The second neural network (NN2) refines the classification within the highlighted area. It is well trained by a comprehensive scenario with many fault parameters being changed including fault type, fault location, fault resistance and fault inception angle, as well as system operating conditions such as loading patterns, topology changes, etc. More scenarios are obtained around the boundaries of the protection zone to achieve more accurate conclusions. The output of NN2 is the combination of all 11 fault types and two fault zones. The final conclusion of NNFDC is drawn by taking into account the outputs from NN1 and NN2 simultaneously. By coordinating the two neural networks, the training process achieves great efficiency when dealing with system-wide events and hence the performance of on-line testing will be greatly improved.

The pattern arrangement for the neural networks is shown in Fig. 4. The pattern is arranged using the post-fault samples of three phase voltage and current signals. Typically, the data window length in each phase is one cycle. The zero sequence values of voltage and current are also included to precisely detect ground faults.

For each element in the input pattern, it is defined as

$$x_k = u(k) + 2u \left(k - \frac{N}{2} \right) + u(k - N) \quad k = 1, 2, \dots, N \quad (2)$$

where u is the signals in related voltage or current phases, k and N have the same definition as in Eq. (1).

Such method of pattern arrangement uses only the superimposed value of the voltage and current waveforms as the major feature. If there is no significant variation of the waveforms during one cycle, which are the most cases in overload and power swing conditions, the pattern will appear as very low value close to the normal system situations. The input pattern is finally normalized into the space of $[-1, 1]$ before training and testing.

3.3.3. Synchronized sampling based differential unit (SSDU)

The synchronized sampling based differential unit is used to distinguish the internal faults from the normal cases and external faults. The scheme is demonstrated using Fig. 5.

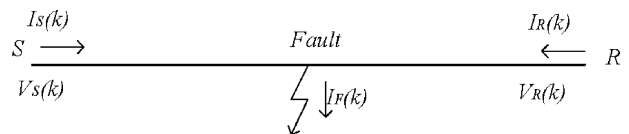

Fig. 5. One-line diagram for a three-phase transmission line.

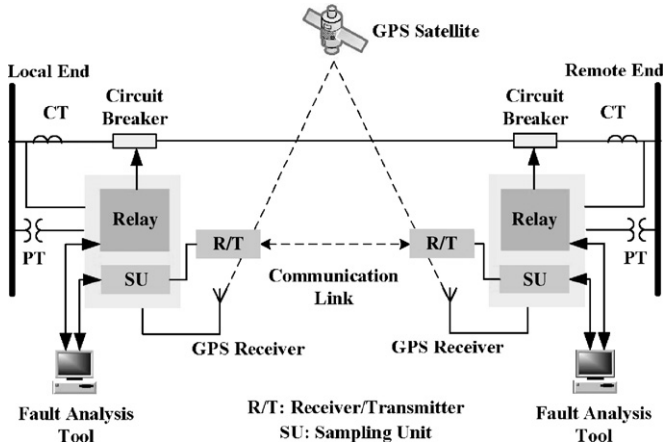

Fig. 6. Hardware configuration of proposed scheme.

just need to select one mode according to Table 1 to calculate the fault location.

3.4. Hardware configuration

A possible hardware configuration of proposed fault analysis scheme is shown in Fig. 6. GPS receiver, high speed communication link and high speed sampling unit are required for SSFL to achieve a high accuracy of fault location. The communication can be through fiber-optic links or high speed Ethernet. The sampling unit can be phasor measurement unit (PMU) or digital fault recorder (DFR). Unlike travelling wave based algorithms which typically need the sampling rate in the order of 300 kHz, the fault location algorithm in this paper typically needs 20 kHz for long transmission line and lower sampling rate (such as 32 points per cycle) for short line. Such a sampling rate can be reached by existing PMU [19], DFR [20], or other devices. The other components in the fault analysis tool, PU, NNFDC, and SSDU, just need the data with low sampling rate. As long as the hardware is satisfied for the SSFL, they can obtain the data by software decimation from the original sampling rate.

3.5. Software implementation

The flowchart of the integrated fault analysis tool is demonstrated using Fig. 7 and described as follows:

- (1) Initialization. $count = 0$.
- (2) Interruption routine. At every Δt_1 , save the new data samples $x(i)$ from the high speed sampling unit to the buffer. Δt_1 is the time step of the high speed sampling unit.
- (3) At Δt_2 , read the newest data $y(j)$ from the buffer. Δt_2 is the time step used in PU, NNFDC and SSDU. Use Eq. (1) to calculate if the potential fault is detected. If yes, $count = count + 1$. Otherwise, $count = 0$, go to step 3.
- (4) If $count \geq M$ (M is the number of samples in one cycle with respect to time step Δt_2), record the present sample point k . load one cycle of decimated post-fault data $y(k - M + 1) \dots y(k)$ to NNFDC and SSDU, and request the related data from remote end. Otherwise, go to step 3.

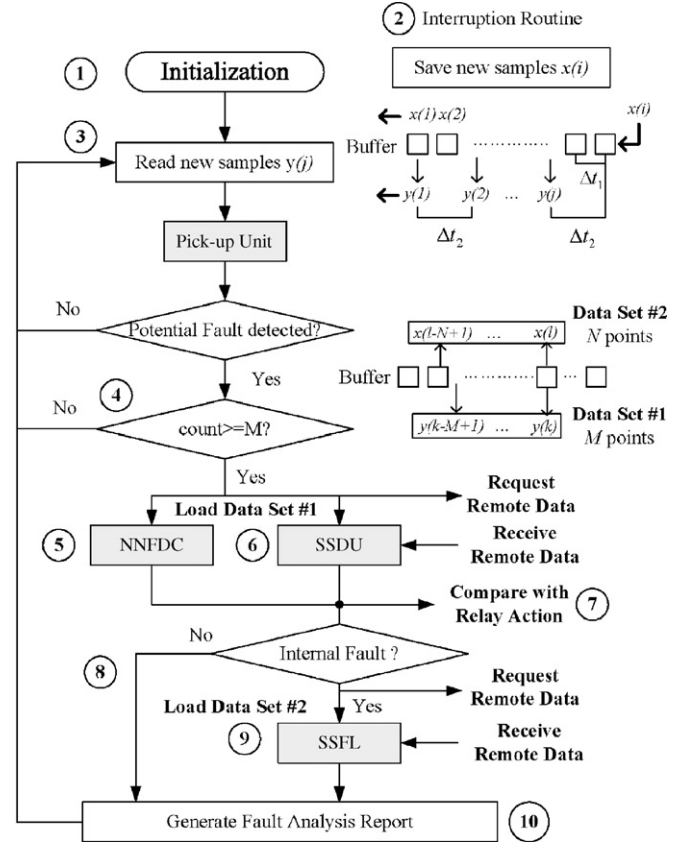

Fig. 7. Flowchart of the integrated fault analysis tool.

- (5) Run fault detection and fault classification using NNFDC.
- (6) Receive data from remote end. Confirm whether there is an internal fault using SSDU.
- (7) Compare the fault analysis result with relay action. Correct the relay misoperations if necessary.
- (8) If internal fault is confirmed, load one cycle of post-fault data with high sampling rate $x(l - N + 1) \dots x(l)$ to SSFL, and request related data from remote end. Note that $x(l) = y(k)$ and N is the number of samples in one cycle with respect to time step Δt_1 . Otherwise, go to step 10.
- (9) Receive data from remote end. According to the fault type concluded by NNFDC, select the mode to locate the fault precisely using SSFL.
- (10) Generate the fault analysis report and send to control center. $count = 0$. Go to step 3.

The time delay for the data transmission from one end of transmission line to the other end can be crudely estimated as:

$$T = \frac{\text{size of data}}{\text{baud rate}} \quad (10)$$

When transmitting a data package of one cycle of three-phase voltage and current samples using a baud rate of 1 Mb/s, the time delays for the SSDU and SSFL are 0.012 and 0.128 s, respectively. Note that the sampling rates are 32 points per cycle for SSDU and 333 points per cycle for SSFL and assume the data type of the sample is *double* (64 bits).

Table 2
The test cases implemented in this paper

Test case	System used	Objective and method
#1	#1	Test the overall dependability/security of the algorithm using randomly generated scenarios under different fault parameters and system conditions
#2	#2	Test the selectivity of the algorithm using randomly generated system-wide disturbances
#3	#2	Test the particular security performance of the algorithm during power swing and out-of-step situation caused by initial disturbances

4. Model implementation and performance evaluation

This paper presents a comprehensive study aimed at evaluating the performance of the integrated algorithm. Three types of tests, with their objectives and methods, are listed in Table 2. The first two tests compare the performance of the integrated fault analysis tool with the distance relay using numerous fault scenarios with different fault parameters and system operating conditions. The third test compares the performance of the integrated fault analysis tool with the distance relay using typical non-fault scenarios. Two complex power system models are selected to implement those tests, as shown in Figs. 8 and 9, respectively.

4.1. Power system models

The two system models are implemented using alternative transient program (ATP) [21]. MATLAB is used to automatically generate a batch of simulation scenarios and test the algorithms [22]. Test #1 is performed using power system #1, which is a model of a real 345 kV system section from CenterPoint Energy [23]. It is suitable to generate realistic fault scenarios in different system conditions. The STP-SKY line is the line of interest in this study. This is a long transmission line represented with distributed line parameters.

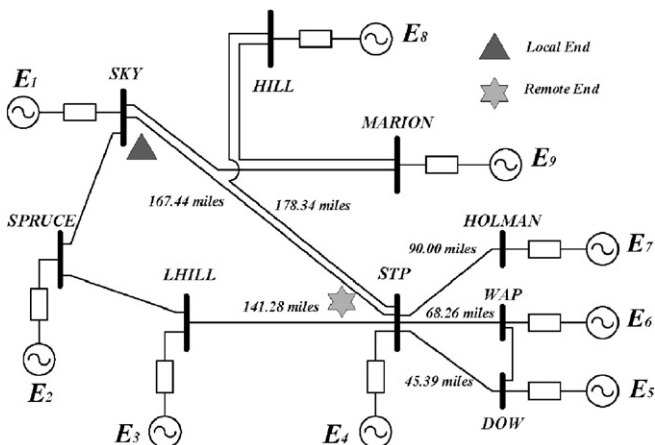

Fig. 8. Power system #1: CenterPoint energy STP-SKY model.

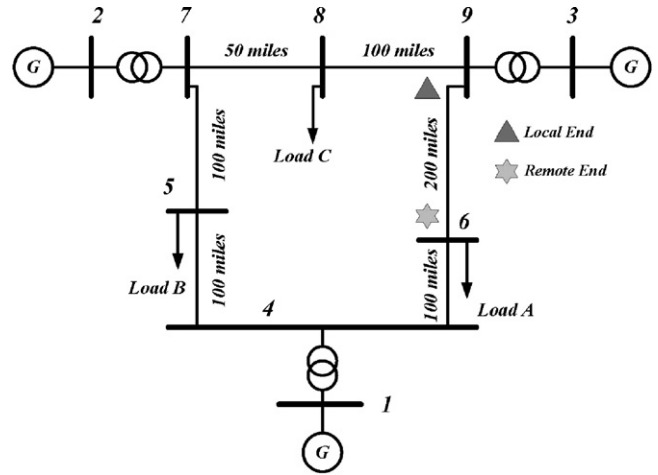

Fig. 9. Power system #2: WECC 9-bus model.

Test #2 and #3 are performed using power system #2, which is the WECC 9-bus system usually used in power flow studies and transient stability studies [24]. Unlike system #1, which is quite “strong” by having too many ideal sources, the 9-bus system represents a typical topology suitable to study the influence of system-wide disturbances. Since the generator data is also available in this system, a “dynamic” model is set up using the embedded synchronous machine component in ATP. The dynamic scenarios such as power swing and out-of-step condition can be simulated as a result. The original lumped line parameters are modified to represent distributed parameters in our studies. The line of interest in this model is line 9-6 with length of 200 miles, as shown in Fig. 9. The use of short line model is not a concern in this paper since many other evaluations show that it has much better accuracy than long line model [14,25].

For both systems, the proposed fault analysis algorithm is installed at the local transmission line ends and the synchronized data used in SSDU and SSFL is transmitted from the remote ends, as marked in Figs. 8 and 9.

4.2. Generation of test scenarios

For test #1, the disturbances involve only the events on SKY-STP line since the faults occurring in other areas have less influence on this line due to the strong in-feed configuration of the system. The integrated algorithm is used for classifying and locating the faults occurring on the SKY-STP line.

Instead of scenarios which would only demonstrate the best performance of the algorithm, the randomly generated scenarios can demonstrate the overall performance and robustness of the proposed algorithm in different situations. The fault parameters are randomly selected from uniform distribution of: all fault types, fault distances (5–95%), fault resistances (0–30 Ω), and fault inception angles (0°–360°). There are four types of system conditions in this test and each has 500 random scenarios: (a) nominal system, (b) weak infeed (disconnect E1 and E9), (c) phase shift (E1 with phase shift –30°), and (d) frequency shift (system frequency of 59 Hz).

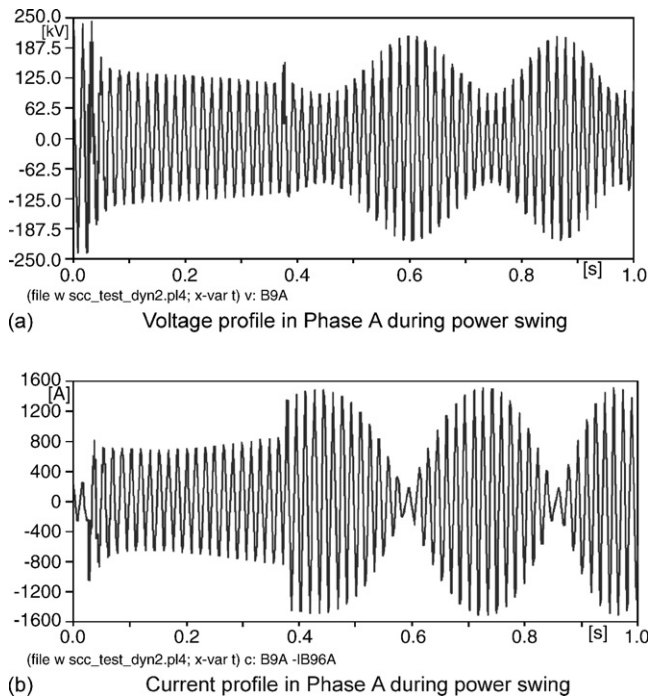

Fig. 10. An example power swing observed at line 9-6 in power system 2.

Test #2 evaluates selectivity of the proposed algorithm on line 9-6 under system-wide events occurring in system #2. The test scenarios are generated randomly using the same fault parameter pool as in test #1. Each of the six lines in system #2 experiences 500 fault cases.

Power swing usually follows line switching, load change, or fault. In test #3, three kinds of typical scenarios outside line 9-6 are selected to imitate the power swing phenomenon. Stable swing is simulated by line switching and line fault that cleared before the critical clearing time (CCT). Unstable swing (out-of-step) is simulated by the most severe three-phase fault cleared after CCT. An example of unstable power swing, which is caused by a three-phase fault on line 4-5 and observed at local end of line 9-6, is shown in Fig. 10.

Traditional distance relay algorithm [26] is implemented in MATLAB along with the integrated fault analysis tool. The comparison is made for each of the three tests. For all three tests, the sampling rate is 20 kHz originally used for SSFL. The data is decimated to 32 points per cycle used for distance relay, as well as the PU, NNFDC and SSDU of the integrated fault analysis tool. The data window for voltage and current samples is fixed to one cycle. In test #1 and #2, the data window is “static” and exactly taken from the post-fault value. In test #3, the data window is “dynamic” and slides throughout the entire power swing process. Before the integrated tool is tested, NNFDC is trained for both of the two power system models with thousands of well designed scenarios, respectively.

4.3. Test results and discussions

The results of test set #1 and test set #2 are listed in Table 3 where the decision errors (%) of each functions against the each

Table 3
Test result for test set #1 and test set #2, error (%)

	Test case #1			Test case #2		
	Norm	Weak	Phase	Freq	Prim	Other
Distance						
Detection	0.600	0.600	1.000	0.800	0	0
Type	1.000	1.400	7.400	1.400	1.200	1.440
Zone	8.600	12.000	15.800	9.000	10.400	11.400
Integrated						
NN: detection	0	0	0	0	0	0
NN: type	0	0	0.200	0.200	0	0
NN: zone	5.800	6.600	5.600	5.400	5.600	2.240
SS: differential	0	0	0	0	0	0
SS: location	0.545	0.585	0.513	0.529	0.720	–

group of test scenarios are shown. The error of fault location shown in the table is the average fault location error of each test set.

The error of fault location for a signal fault scenario is defined as:

$$\text{Error (\%)} = \frac{|\text{actual location} - \text{computed location}|}{\text{line length}} \times 100 \quad (11)$$

The functions in distance relay and integrated tools are broken down to make a clear comparison. In test set #1, “norm”, “weak”, “phase” and “freq” stand for nominal system, weak infeed, phase shift and frequency shift respectively. In test set #2, “prim” and “other” stand for the events on the primary line 9-6 and events on the other lines, respectively.

The test results indicate that for all test sets, the integrated tool has much better performance than distance relay. For all test sets, the pick-up unit can find the fault inception time within two samples with respect to 32 points per cycle, which is sufficient for NNFDC, SSDU and SSFL. NNFDC has the exactly same functions as distance relay. The result shows an overall improvement of the performance over distance relay. NNFDC especially provides a good classification for the fault types. SSDU successfully differentiates all the internal faults from the normal cases and external faults. It can provide an exact confirmation when NNFDC is confused with the events around the zone boundaries. SSFL provides very good accuracy of fault location. The performance of integrated tool is less affected by different fault parameters, system operating conditions and system-wide events.

The desired behavior of line protection in test #3 is that it should not initiate a trip signal during the power swing. The reason is that power swing, whether stable or unstable, is not a fault within the line of interest. Therefore, the distance relay or other fault detection algorithm should not trip during the power swing unless it receives the order by other out-of-step relays.

The results of test #3 listed in Table 4 demonstrate the behavior of distance relay and the integrated tool during the power swing caused by different situations. The result indicates that the distance relay will operate during some situation but the integrated tool will not be affected in any case.

Table 4
Test result for power swing simulation

Swing	Case	Line	Distance relay	Integrated tool
Stable	Line open	6-4	Stand-by	Stand-by
		9-8	Stand-by	Stand-by
		4-5	Stand-by	Stand-by
		5-7	Stand-by	Stand-by
		7-8	Stand-by	Stand-by
	Line fault (clear time <CCT)	4-5	Zone 3 pick-up	Stand-by
		5-7	Stand-by	Stand-by
Unstable	Line fault (clear time >CCT)	4-5	Zone 1 trip	Stand-by
		5-7	Zone 1 trip	Stand-by
		7-8	Zone 1 trip	Stand-by

5. Conclusion

This paper proposes an integrated transmission line fault analysis tool that can offer accurate fault detection, classification, internal/external fault differentiation, and fault location. The integrated fault analysis tool is primarily based on two different principles. The two techniques complement each other to achieve complete fault analysis functions and provide self-confirmation. The integrated tool uses time domain data as inputs. The data processing errors in calculating phasors are avoided. The tedious setting coordination work when traditional relays are applied is also avoided.

The design of the integrated tool takes into account the application issues of the prototypes of both algorithms. The solutions are given in this paper. The test results obtained from the comprehensive tests using two complex power system models indicate that the integrated tool has better dependability/security and selectivity than distance relay.

Acknowledgements

The authors would like to acknowledge the financial support from NSF I/UCRC Power Systems Engineering Research Center (PSerc), project S-19 titled “Detection, Prevention and Mitigation of Cascading Events”.

References

- [1] A.G. Phadke, J.S. Thorp, Expose hidden failures to prevent cascading outages, *IEEE Comput. Appl. Power* 9 (3) (1996) 20–23.
- [2] S. Tamronglak, S.H. Horowitz, A.G. Phadke, J.S. Thorp, Anatomy of power system blackouts: preventive relaying strategies, *IEEE Trans. Power Delivery* 11 (2) (1996) 708–715.
- [3] A.A. Girgis, M.B. Johns, A hybrid expert system for faulted section identification, fault type classification and selection of fault location algorithms, *IEEE Trans. Power Delivery* 4 (2) (1996) 978–985.
- [4] J. Jiang, C. Chen, C. Liu, A new protection scheme for fault detection, direction discrimination, classification, and location in transmission lines, *IEEE Trans. Power Delivery* 18 (1) (2003) 34–42.
- [5] M. Oleskovicz, D.V. Coury, R.K. Aggarwal, A complete scheme for fault detection, classification and location in transmission lines using neural networks, *Developments in Power System Protection*, 2001, in: *Proceedings of the 7th International Conference on (IEE)*, 2001, pp. 335–338.
- [6] M. Kezunovic, B. Perunicic, Automated transmission line fault analysis using synchronized sampling at two ends, *IEEE Trans. Power Syst.* 11 (1) (1996) 441–447.
- [7] Z.Q. Bo, F. Jiang, Z. Chen, Transient based protection for power transmission systems, *IEEE PES Winter Meeting*, (3) 2000, pp. 1832–1837.
- [8] M. Chamia, S. Liberman, Ultra high speed relay for EHV/UHV transmission lines – development, design and application, *IEEE Trans. PAS* 97 (1978) 2104–2112.
- [9] C. Christopoulos, D. Thomas, A. Wright, Scheme, based on traveling waves for the protection of major transmission lines, *IEE Proc. Part C* 135 (1988) 63–73.
- [10] A.T. Johns, R.K. Aggarwal, Z.Q. Bo, A novel non-unit protection technique for EHV transmission systems based on fault-generated noise. Part 1. Signal measurement, *IEE Proc. Gener. Trans. Distrib.* 141 (2) (1994) 133–140.
- [11] R.K. Aggarwal, A.T. Johns, Z.Q. Bo, A novel non-unit protection technique for EHV transmission systems based on fault-generated noise. Part 2. Signal processing, *IEE Proc. Gener. Trans. Distrib.* 141 (2) (1994) 133–140.
- [12] Z.Q. Bo, M.A. Redfern, G.C. Weller, Positional protection of transmission line using fault generated high frequency transient signals, *IEEE Trans. Power Delivery* 15 (3) (2000) 888–894.
- [13] S. Vasilic, M. Kezunovic, Fuzzy ART neural network algorithm for classifying the power system faults, *IEEE Trans. Power Delivery* 20 (2) (2005) 1306–1314.
- [14] M. Kezunovic, B. Perunicic, J. Mrkic, An accurate fault location algorithm using synchronized sampling, *Electric Power Syst. Res.* 29 (3) (1994) 161–169.
- [15] G.A. Carpenter, S. Grossberg, ART2: self-organization of stable category recognition codes for analog input patterns, *Appl. Opt.* 26 (23) (1987) 4919–4930.
- [16] J. Keller, M.R. Gary, J.A. Givens, A fuzzy k-nearest neighbor algorithm, *IEEE Trans. Syst. Man Cyber.* 15 (4) (1985) 580–585.
- [17] Working Group C6 of the System Protection Subcommittee of the IEEE Power System Relaying Committee, Wide area protection and emergency control, Technical Report, 2002 [Online] Available: <http://www.pes-psrc.org/>.
- [18] A. Gopalakrishnan, M. Kezunovic, S.M. McKenna, D.M. Hamai, Fault location using distributed parameter transmission line model, *IEEE Trans. Power Delivery* 15 (4) (2000) 1169–1174.
- [19] Technical reference manual: Phasor measurement terminal RES 521*1.0, ABB, [Online] Available: <http://www.abb.com>.
- [20] TR-2000 multi-function recorder brochure, Ametek power instrument, [Online] Available: <http://www.ametekpower.com>.
- [21] CanAm EMTF User Group, Alternative Transient Program (ATP) Rule Book, Portland, 1992.
- [22] The MathWorks Inc., Using MATLAB, Natick, 2002.
- [23] D. Ristanovic, S. Vasilic, M. Kezunovic, Design and implementation of scenarios for evaluating and testing distance relays, in: *North American Power Symposium – NAPS*, College Station, TX, 2001.
- [24] P.M. Anderson, A.A. Fouad, *Power System Control and Stability*, vol. I, The Iowa State University Press, Ames, Iowa, 1977, p. 38.
- [25] N. Zhang, M. Kezunovic, A study of synchronized sampling based fault location algorithm performance under power swing and out-of-step conditions, in: 2005 IEEE St. Petersburg PowerTech’05, St. Petersburg, Russia, June, 2005.
- [26] W.A. Lewis, S. Tippet, Fundamental basis for distance relaying on 3-phase systems, *AIEE Trans.* 66 (1947) 694–708.

Nan Zhang received his B.S. and M.S. degrees from Tsinghua University, Beijing, China, both in electrical engineering, in 1999 and 2002, respectively. Since June 2002, he has been with Texas A&M University pursuing his Ph.D. degree. His research interests are power system analysis, power system protection, power system stability, system-wide disturbances, as well as signal processing and artificial intelligence applications in power systems.

Mladen Kezunovic received his Dipl. Ing. degree, the M.S. and Ph.D., all in electrical engineering, in 1974, 1977 and 1980, respectively. Dr. Kezunovic's industrial experience is with Westinghouse Electric Corporation in the USA, and the Energoinvest Company in Europe. He was a Visiting Associate Professor at Washington State University in 1986–1987. He has been with Texas A&M University since 1987 where he is the Eugene E. Webb Professor and Director of

Electric Power and Power Electronics Institute. His main research interests are digital simulators and simulation methods for equipment evaluation and testing as well as application of intelligent methods to control, protection and power quality monitoring. Dr. Kezunovic is a registered professional engineer in Texas, and a Fellow of the IEEE.